



**Originalbetriebsanleitung | Original instructions |
Traduction de la notice originale**

DH 20 / DH 35 / DH 35 H / DH 65 / DH 65 H

| de | en | fr |

Table of contents

Information on the use of these instructions	57
Symbols.....	57
Safety	58
Intended use	59
Reasonably foreseeable misuse.....	60
Personnel qualification.....	60
Safety signs and labels on the device	60
Residual risks	61
Information about the device	63
Device description.....	63
Device depiction.....	64
Transport and storage	65
Transport.....	65
Storage	65
Assembly and start-up	66
Scope of delivery	66
Unpacking the device.....	66
Assembly.....	66
Start-up of the device	75
Operation	76
Errors and faults	78
Error messages	79
Maintenance	80
Maintenance intervals	80
Maintenance and care log.....	80
Activities required before starting maintenance.....	81
Cleaning the housing	81
Visual inspection of the inside of the device for dirt.....	81
Refrigerant circuit.....	82
Replacing and/or cleaning the air filter.....	83
Technical annex	86
Technical data.....	86
Disposal	105
EU Declaration of Conformity	106

Information on the use of these instructions

Symbols



Danger

This symbol indicates dangers to the life and health of persons due to extremely flammable gas.



Danger

This symbol indicates dangers to the life and health of persons due to flammable refrigerants.



Warning of electrical voltage

This symbol indicates dangers to the life and health of persons due to electrical voltage.



Warning

This signal word indicates a hazard with an average risk level which, if not avoided, can result in serious injury or death.



Caution

This signal word indicates a hazard with a low risk level which, if not avoided, can result in minor or moderate injury.

Notice

This signal word indicates important information (e.g. material damage), but does not indicate hazards.



Info

Information marked with this symbol helps you to carry out your tasks quickly and safely.



Follow the manual

Information marked with this symbol indicates that the instructions must be observed.

Safety

Read this manual carefully before starting or using the device. Always store the manual in the immediate vicinity of the device or its site of use.



Warning

Read all safety warnings and all instructions.

Failure to follow the warnings and instructions may result in electric shock, fire and/or serious injury.

Save all warnings and instructions for future reference.

This appliance can be used by children aged from 8 years and above and persons with reduced physical, sensory or mental capabilities or lack of experience and knowledge if they have been given supervision or instruction concerning use of the appliance in a safe way and understand the hazards involved.

Children shall not play with the appliance. Cleaning and user maintenance shall not be done by children without supervision.

- Do not use the device in potentially explosive rooms or areas and do not install it there.
- Do not use the device in an aggressive atmosphere.
- Let the device dry out after a wet clean. Do not operate it when wet.
- Do not use the device with wet or damp hands.
- Do not expose the device to directly squirting water.
- Do not cover the device during operation.
- Do not sit on the device.
- This appliance is not a toy. Keep away from children and animals.
- Check the device occasionally during operation.
- Ensure that all electric cables outside of the device are protected from damage (e.g. caused by animals). Never use the device if electric cables or the power connection are damaged!
- Check accessories and connection parts for possible damage prior to every use of the device. Do not use any defective devices or device parts.
- The mains connection must correspond to the specifications in the Technical annex.
- Observe the device's power input, cable length and intended use when selecting extensions to the power cable. Completely unroll extension cables. Avoid electrical overload.
- Insert the mains plug into a properly fused mains socket.
- Do not under any circumstances use the device if you detect damages on the mains plug or power cable. If the power cable is damaged, it must be replaced by the manufacturer, its service agent or similarly qualified persons in order to avoid a hazard. Defective power cables pose a serious health risk!
- Before carrying out maintenance, care or repair work on the device, remove the mains plug from the mains socket. Hold onto the mains plug while doing so.
- Disconnect the power cable from the mains socket when the device is not in use.
- Observe the storage and operating conditions (see Technical data).
- Make sure that the air inlet and outlet are not obstructed.
- Make sure that the suction side is kept free of dirt and loose objects.
- Never insert any objects or limbs into the device.

- Do not remove any safety signs, stickers or labels from the device. Keep all safety signs, stickers and labels in legible condition.
- Discharge the collected condensate before transport and storage. Do not drink it. Health hazard!
- Only use original spare parts, for otherwise safe and functional operation cannot be ensured.
- Only install the device in compliance with the national installation regulations.
- Only install, operate and store the device in a room measuring more than 4 m².
- Store the device in a way that no mechanical damage can occur.
- The entire refrigerant circuit is a maintenance-free, hermetically sealed system and may only be maintained or repaired by specialist companies for cooling and air-conditioning or by the manufacturer.

Safety instructions for servicing the refrigerant circuit:

- Every person working with or at the refrigerant circuit must be able to provide a certificate of qualification issued by a body accredited by the industry, demonstrating their competence in the safe use of refrigerants based on a procedure well-known in the industry.
- Service work may only be carried out in accordance with the manufacturer's specifications. If maintenance and repair work require the support of additional persons, the person trained in handling flammable refrigerants shall continuously supervise the work carried out.
- Do not use any means other than those recommended by the manufacturer for accelerating the defrosting process.
- Do not drill into or burn.
- Please note that the refrigerant is odourless.
- Observe the national regulations for gas installations.
- Observe the maximum refrigerant capacity in the technical data.
- R290 is a refrigerant that complies with European environmental regulations. No part of the cooling circuit may be perforated.

Intended use

Only use the device as a stationary industrial dryer for drying and dehumidifying room air whilst adhering to the technical data and safety instructions.

Intended use comprises:

- drying and dehumidifying:
 - production plants, underground rooms
 - store rooms, archives, laboratories, swimming pool halls, clothes drying rooms
 - rooms and areas after water damage caused by burst pipes or flooding
- keeping dry of:
 - instruments, devices, files
 - moisture-sensitive goods, loads, etc.

Observe the local provisions when installing and using the device in the previously mentioned environments (e.g. indoor swimming pools).

Any use other than the intended use is regarded as misuse.

Reasonably foreseeable misuse

- Do not place any objects, e.g. clothing, on the device.
- Do not use the device out of doors.
- Do not use the device in the immediate vicinity of swimming pools, bathtubs and showers.
- Never immerse the device in water.
- Never use a defective connection cable or a defective or incorrectly connected cable.
- Do not make any unauthorised modifications, alterations or structural changes to the device.

Personnel qualification

People who use this device must:

- be aware of the dangers that occur when working with electric devices in damp areas.
- have read and understood the instructions, especially the Safety chapter.

Installation work which requires the housing to be opened must only be carried out by plumbers as well as by specialists in cooling and air-conditioning and by qualified electricians.

Installation and maintenance work on the electrical system must only be carried out by a qualified electrician.

Installation and maintenance work on the cooling and air-conditioning circuit must only be carried out by a specialist in cooling and air-conditioning.

Safety signs and labels on the device

Notice

Do not remove any safety signs, stickers or labels from the device. Keep all safety signs, stickers and labels in legible condition.

The following safety signs and labels are attached to the device:



DH 20

WARNING • WARNUNG • ATTENTION

DE Das Gerät muss in einem Raum mit einer Grundfläche größer als 4 m² aufgestellt, betrieben und gelagert werden.

EN Appliance shall be installed, operated and stored in a room with floor area larger than 4 m².

FR L'appareil doit être installé, utilisé et entreposé dans une pièce avec une surface supérieure à 4 m².



DH 35 / DH 35 H / DH 65 / DH 65 H

WARNING • WARNUNG • ATTENTION

- DE** Das Gerät muss in einem Raum mit einer Grundfläche größer als 4 m² aufgestellt, betrieben und gelagert werden.
- EN** Appliance shall be installed, operated and stored in a room with floor area larger than 4 m².
- FR** L'appareil doit être installé, utilisé et entreposé dans une pièce avec une surface supérieure à 4 m².

Follow the manual

This symbol indicates that the operating manual must be observed.

Follow the repair manual

Disposal, maintenance and repair work of the refrigerant circuit may only be carried out in accordance with the manufacturer's specifications and by persons having a certificate of qualification. A corresponding repair manual is available from the manufacturer upon request.

en

Residual risks

DH 20

⚠ Danger
Natural refrigerant propane (R290)!

H220 – Extremely flammable gas.

H280 – Contains gas under pressure; may explode if heated.

P210 – Keep away from heat, sparks, open flames and other ignition sources. No smoking.

P377 – Leaking gas fire: Do not extinguish, unless leak can be stopped safely.

P410+P403 – Protect from sunlight. Store in a well-ventilated place.

 DH 35 / DH 35 H /
 DH 65 / DH 65 H

⚠ Danger
Refrigerant R454C

H221 – Flammable gas.

H280 – Contains gas under pressure; may explode if heated.

P210 – Keep away from heat, sparks, open flames and other ignition sources. No smoking.

P377 – Leaking gas fire; Do not extinguish, unless leak can be stopped safely.

P381 – Eliminate all ignition sources if safe to do so.

P410 and P403 – Protect from sunlight. Store in a well-ventilated place.

DH 20 / DH 35 /
DH 35 H / DH 65 /
DH 65 H



⚠ Warning of electrical voltage

Work on the electrical components must only be carried out by an authorised specialist company!



⚠ Warning of electrical voltage

Risk of electric shock!

Before any work on the device, remove the mains plug from the mains socket! Do not touch the mains plug with wet or damp hands. Hold onto the mains plug while pulling the power cable out of the mains socket.



⚠ Warning

Dangers can occur at the device when it is used by untrained people in an unprofessional or improper way! Observe the personnel qualifications!



⚠ Warning

A falling device can cause injuries! **Always transport the device with the help of other persons.** Never stand below the device when it is suspended. Ensure adequate stability of the device's wall fixing.



⚠ Warning

The device is not a toy and does not belong in the hands of children.



⚠ Warning

Risk of suffocation!

Do not leave the packaging lying around. Children may use it as a dangerous toy.

Notice

Do not operate the device without an air filter inserted into the air inlet!

Without the air filter, the inside of the device will be heavily contaminated. This can reduce the performance and result in damage to the device.

Information about the device

Device description

The dehumidifiers of the DH series use the principle of condensation to automatically dehumidify rooms.

The fan draws damp room air through the air inlet, the evaporator and the condenser located behind it. The air is cooled at the cold evaporator until it is below the dew point. Water vapour contained in the room air precipitates on the evaporator fins as condensation or frost. The dehumidified, cooled air is rewarmed at the condenser and blown out at a temperature of approx. 5 °C above room temperature (see "Condensation principle" illustration in the annex).

The drier air, thus conditioned, mixes with the air in the room via the air outlet. The humidity in the room where the device is positioned is reduced as air constantly circulates through the device. Depending on the air temperature and the relative humidity, the condensed water either drops continuously or only during the defrost phase through the pre-assembled condensation drain hose and is discharged from the device.

The device features a hygrostat with control dial for setting the desired humidity level. The ventilation mode can be set.

The device can reduce the relative humidity of a room to approx. 40 %.

A good comfort level for people using a room for normal use is between 50 % and 65 % relative humidity.

Because of the heat radiation generated during operation, the room temperature may rise slightly.

A high humidity level in the air (starting at 70 % RH) provides the perfect breeding ground for mould. However, the room air must not be too dry either (< 40 % RH). Materials such as leather or rubber become porous, and wood becomes brittle and fissured.

The device is protected against dripping water (IPX2).

The devices DH 35 H and DH 65 H are delivered with an electric heater. In all other respects, the devices comply with the DH 35 and DH 65. A heating coil can be optionally installed into the devices DH 35 and DH 65. A wired remote control can be connected to all four variants.

Device depiction

DH 20

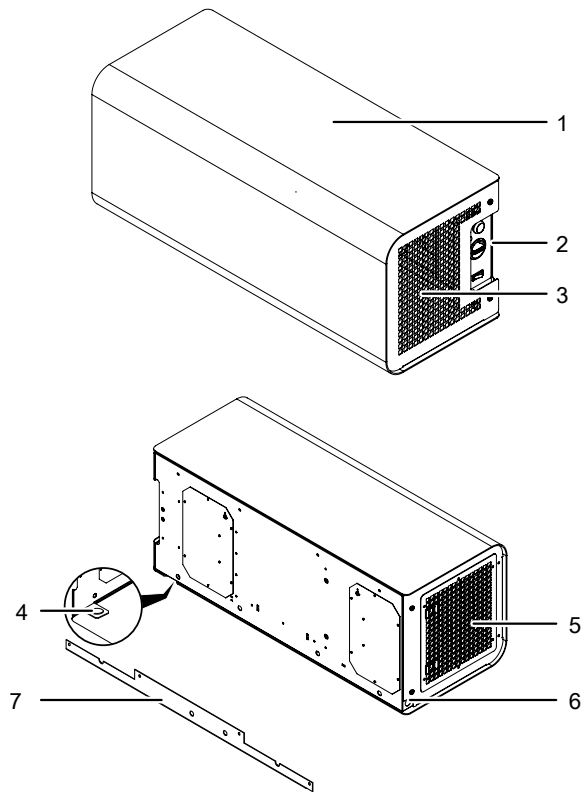

DH 35 / DH 35 H / DH 65 / DH 65 H

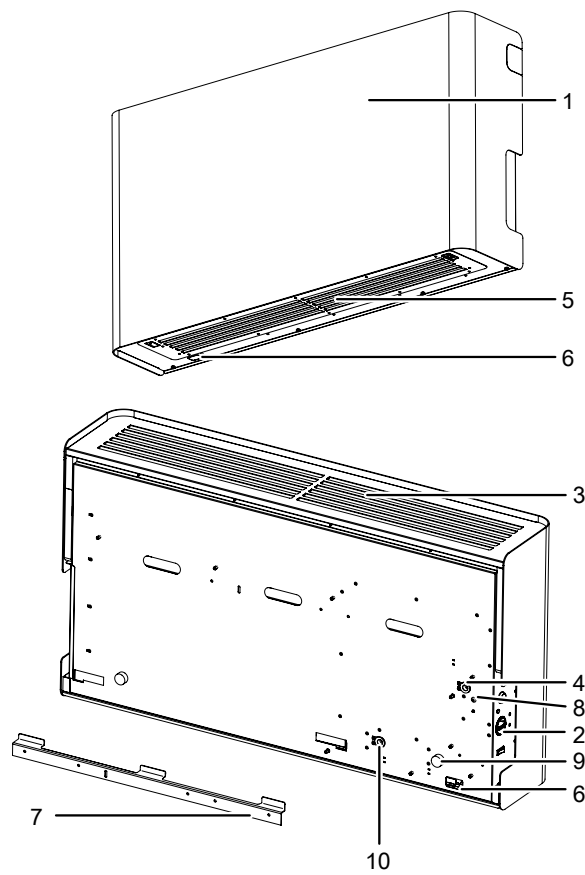

No.	Designation
1	Housing
2	Control panel
3	Air outlet
4	Feed-through for mains connection cable (connection inside the device)
5	Air inlet with air filter
6	Feed-through for condensation hose (connection inside the device)
7	Suspension rail
8	Feed-through for wired remote control (connection inside the device)
9	Spacer
10	Feed-through for the connection cable of the electric heater (connection inside the device)

Transport and storage

Notice

If you store or transport the device improperly, the device may be damaged.

Note the information regarding transport and storage of the device.

Transport

Please note that additional transport regulations might apply to devices containing flammable refrigerants. The equipment's arrangement and the maximum number of components to be transported together can be gathered from the applicable transport regulations.

Before transporting the device, observe the following:

- The DH 20 can be carried by one or two people. Use a pallet jack or hand truck to transport the DH 35, DH 35 H, DH 65 and DH 65 H.
- Hold onto the mains plug while pulling the power cable out of the mains socket.
- Drain the remaining condensate from the device.
- Do not use the power cable to drag the device.

After transporting the device, proceed as follows:

- Set up the device in an upright position after transport.
- If the device has been moved, allow it to stand for 30 minutes before using it again so that the lubricating oil can flow back into the compressor. Acting contrary might lead to compressor damage and a malfunctioning device.

Storage

Before storing the device, proceed as follows:

- Hold onto the mains plug while pulling the power cable out of the mains socket.

When the device is not being used, observe the following storage conditions:

- Only store the device in a room measuring more than 4 m².
- Only position the device in rooms where there is no source of ignition (e.g. open flames, an active gas appliance or an electric heater).
- Store the device in a dry location and protected from frost and heat.
- If required, use a cover to protect the device from invasive dust.
- Place no further devices or objects on top of the device to prevent it from being damaged.

Assembly and start-up

Scope of delivery

- 1 x Device
- 1 x Condensation hose, diameter 16 mm, length 80 cm
- 1 x Suspension rail
- 1 x Manual

Unpacking the device

1. Open the cardboard box and take the device out.
2. Completely remove the packaging.

Assembly

Installation instructions:

- Two people are required to install the DH 20, DH 35 and DH 35 H, and three people are required to install the DH 65 and DH 65 H. To lift the device, use a forklift or an elevating truck as appropriate.
- Protect the device on site, especially in wet areas, with a residual current device (RCD) which complies with the relevant regulations.
- Only install the device in rooms where potentially leaking refrigerant cannot accumulate.
- When assembling the device, keep a sufficient distance to heat sources.
- Note that the device must be hanging in its final position for at least 30 minutes after installation before you switch it on.
- Select screw and wall plug sizes suitable for the weight of the device (see Technical data) and the structure of the wall.
- When assembling the device, observe the minimum distance from adjacent walls or other objects as described in the Technical Data chapter.

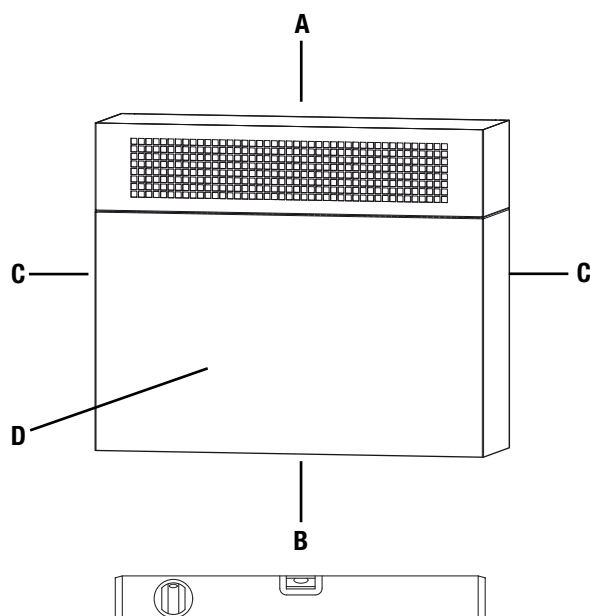

Electrical connection (voltage supply)

Notice

A short piece of cable is attached to the device upon delivery. Do not use this short piece of cable; remove it and dispose of it properly! It is only used for testing at the factory and is not intended to be used by the end customer!

A power cable for connection to the mains is not supplied. Observe the country-specific regulations and the technical data in the annex when purchasing a separate power cable with mains plug. The mains connection cable must be connected by a qualified electrician.

- ✓ The device must be connected electrically before being mounted on the wall.
 - ✓ Observe the country-specific specifications when connecting the mains connection cable.
 - ✓ Make sure that no current is flowing through the mains connection cable to be connected.
1. Loosen the two Phillips screws (11) at the feed-through for the mains connection cable (4).

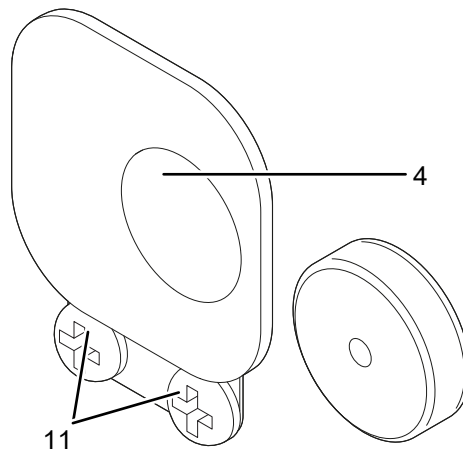

2. Pull the mains connection (12) slightly out of the feed-through (4) and use a tool (e.g. a screwdriver) to push the two clamping tabs (13) between the housing and the mains connection inwards.

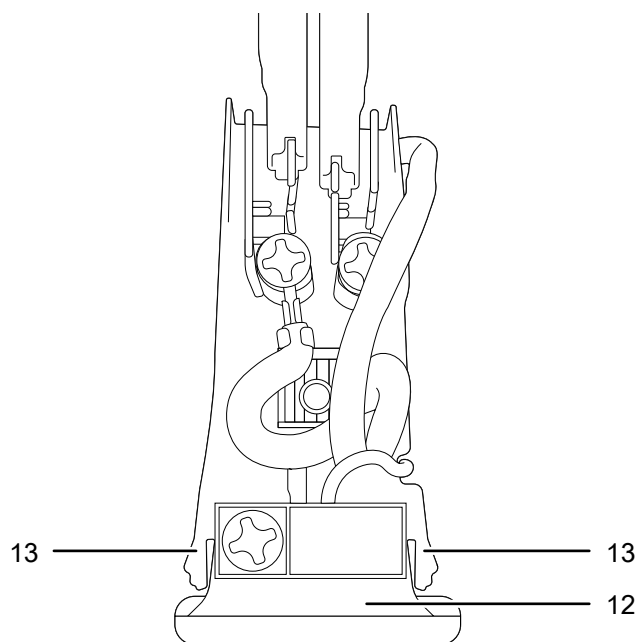

3. Wire the mains connection (12) according to your country-specific regulations.



4. Insert the mains connection with the mains connection cable (15) into the feed-through and tighten the connection using the two Phillips screws.

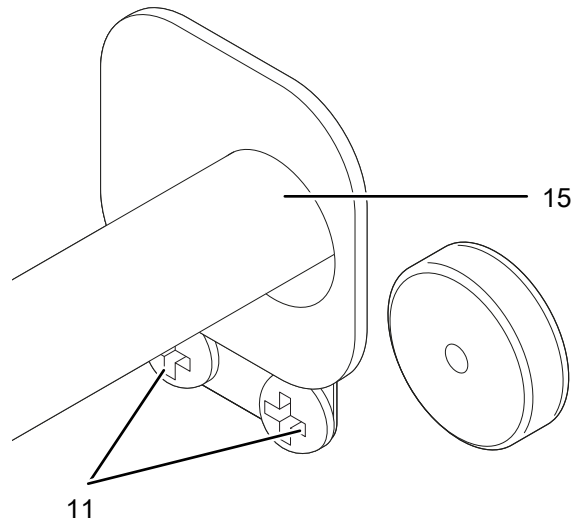

Electrical connection of the optional electric heater (DH 35 H / DH 65 H)

- ✓ The device must be connected electrically before being mounted on the wall.
 - ✓ Observe the country-specific specifications when connecting.
 - ✓ Make sure that no current is flowing through the connection cable of the electric heater.
1. Loosen the two Phillips screws (16) at the feed-through for the electric heater (10).

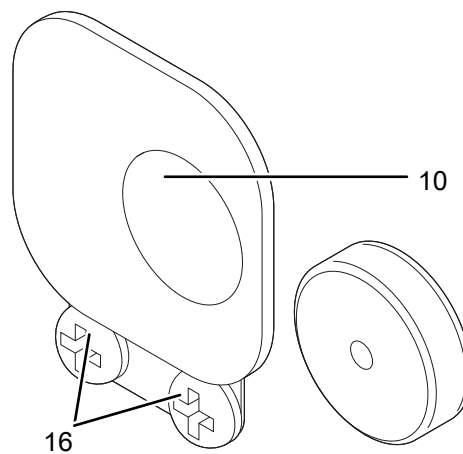

2. Pull the connection (17) slightly out of the feed-through (10) and use a tool (e.g. a screwdriver) to push the two clamping tabs (18) between the housing and the connection inwards.

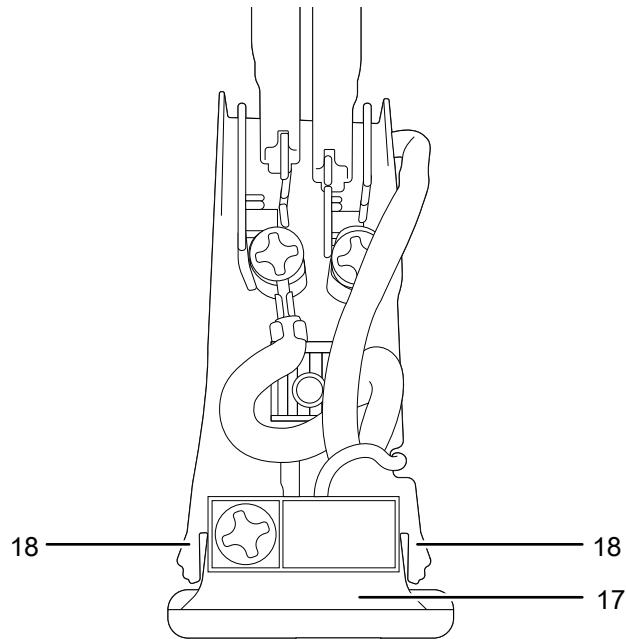

3. Wire the electrical connection (17) according to your country-specific regulations.
4. Insert the electrical connection with the connection cable (19) into the feed-through and tighten the electrical connection using the two Phillips screws.

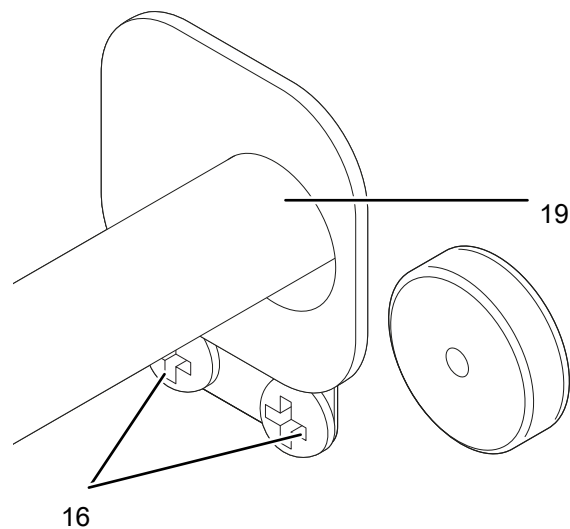

**Wall mounting
(DH 20)**

Notice

Mount the device on a solid wall made of bricks and concrete. Avoid mounting on walls made of wood or plasterboard, as the device may otherwise make excessive noise during operation.

✓ The power cable is connected inside the device.

1. Stick the drilling template horizontally on the wall and drill the 8 holes into the wall.

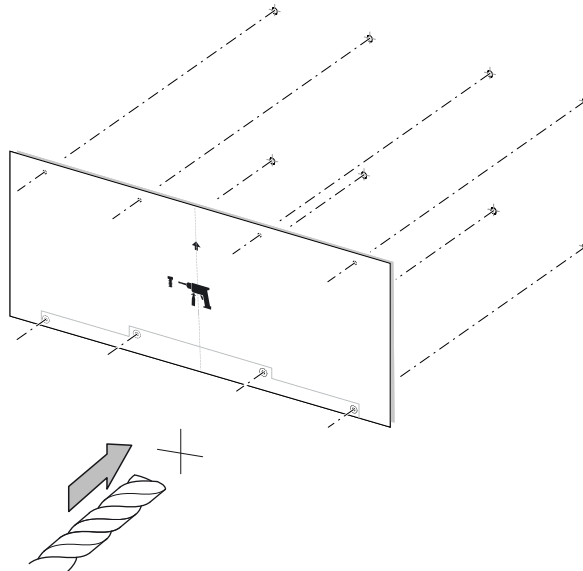

2. Remove the drilling template from the wall.
3. Insert suitable wall plugs into the drill holes.
4. Place the suspension rail (7) on the wall and screw it on using four screws.

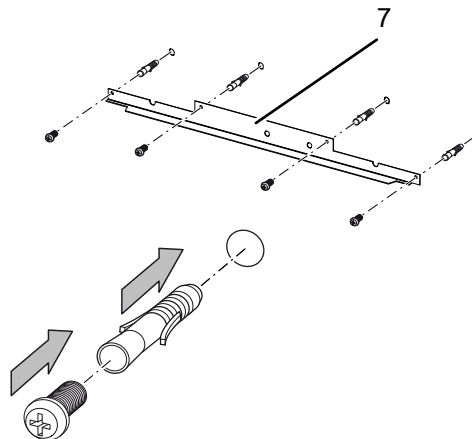

5. Loosen the screws at the housing (1) and remove the housing from the device.

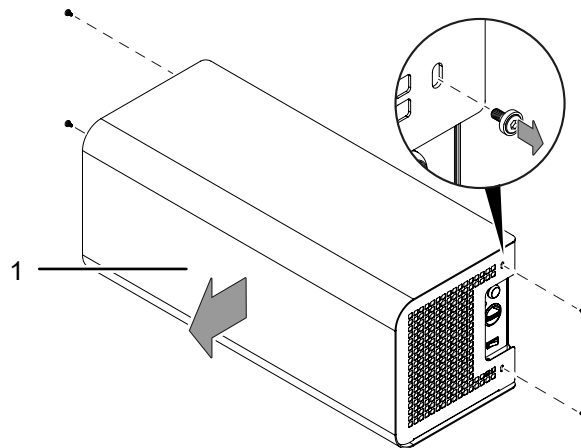

6. Place the device on the suspension rail (7) and tighten the screws.

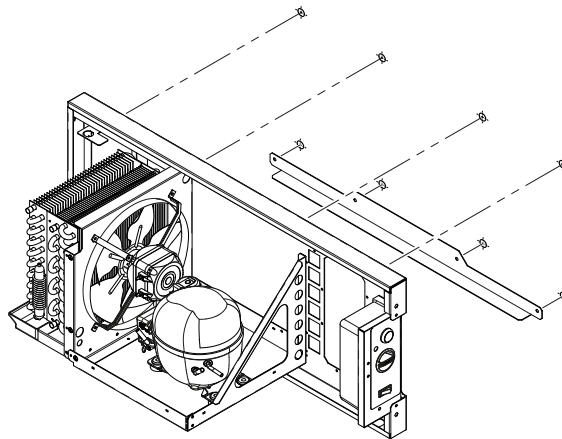

7. Connect the condensation hose (20) inside the device and route it out of the device via the feed-through for the condensation hose (6). Do not kink the condensation hose.

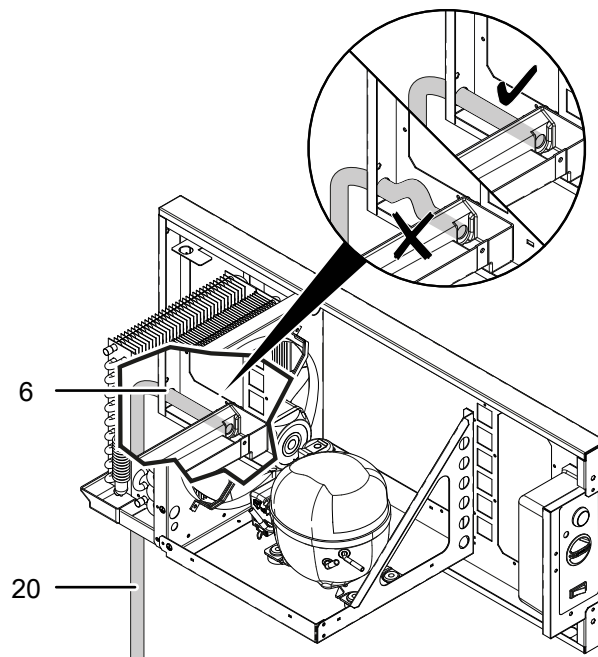

8. Reattach the housing (7) and tighten the screws.

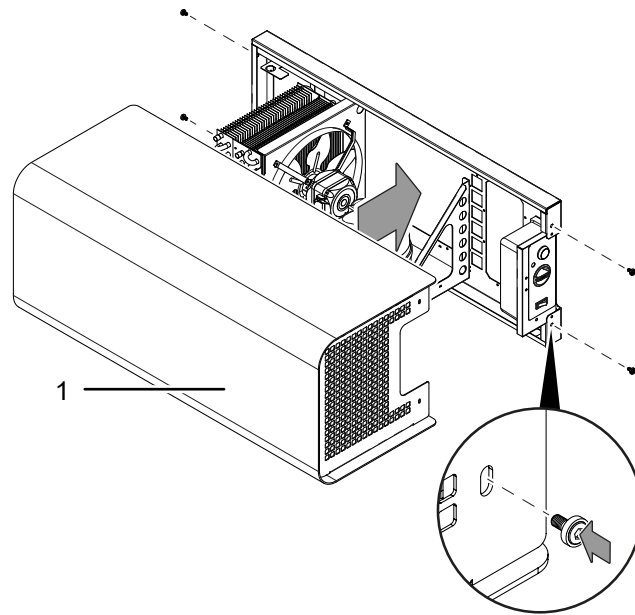

9. Position the end of the condensation hose (20) near a water drain. For larger distances, a longer hose of the same type (16 mm diameter) can also be used.

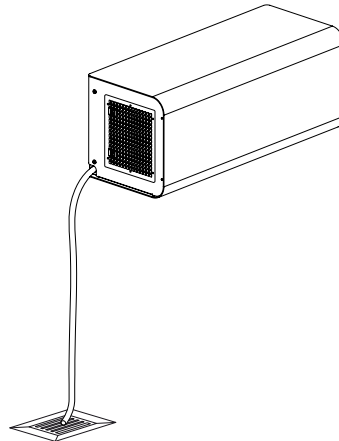

10. Regularly check the condensation hose for obstructions or kinks.

Wall mounting
(DH 35 / DH 35 H /
DH 65 / DH 65 H)

Notice

Mount the device on a solid wall made of bricks and concrete. Avoid mounting on walls made of wood or plasterboard, as the device may otherwise make excessive noise during operation.

✓ The power cable is connected inside the device.

1. Position the suspension rail (7) horizontally on the wall and mark the drill holes.

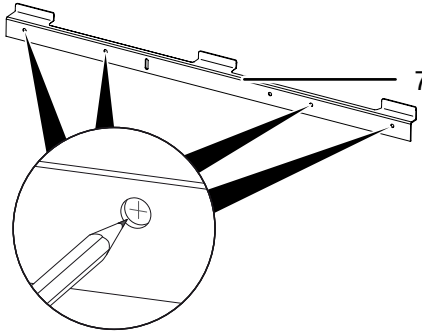

2. Drill the holes into the wall.

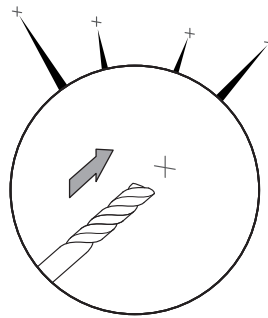

3. Insert suitable wall plugs into the drill holes.

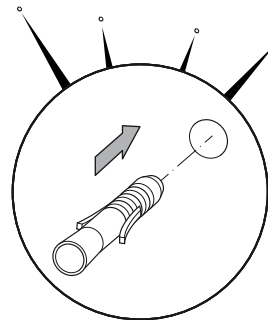

4. Screw the suspension rail (7) into place.

5. Hang the device on the suspension rail (7). Utilize the help of one or two other persons as well as suitable lifting gear to do so.

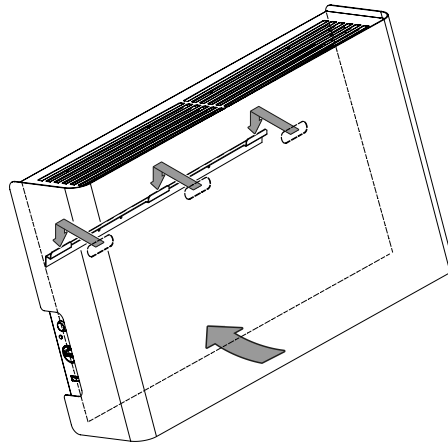

6. Loosen the screws at the housing and remove the housing (1).

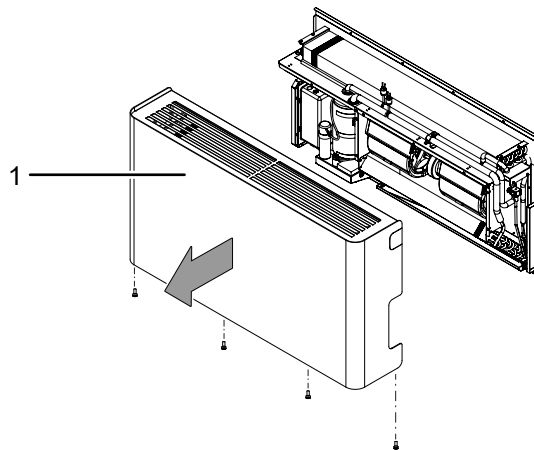

7. Route the condensation hose (20) through the feed-through for the condensation hose (6) at the rear of the device and connect the hose inside the device. Do not kink the condensation hose.

⇒ Alternatively, the condensation hose can also be routed through the feed-through (6) at the bottom of the device.

8. Reattach the housing (1) and tighten the screws.

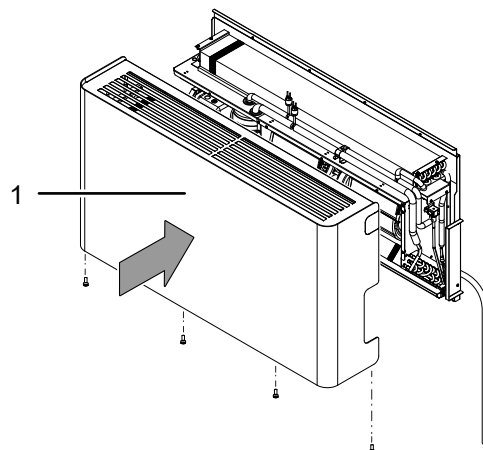

9. Position the end of the condensation hose (20) near a water drain. For larger distances, a longer hose of the same type (16 mm diameter) can also be used.

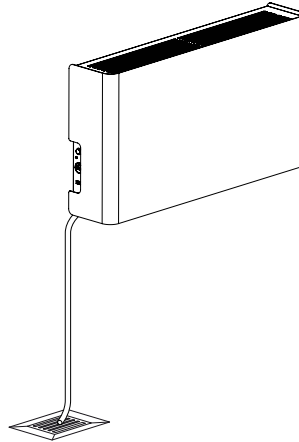

10. Regularly check the condensation hose for obstructions or kinks.

Start-up of the device

Observe the following instructions:

- Ensure that the extension cables are completely unrolled.
- Make sure that no curtains or other objects interfere with the air flow.
- Before restarting the device, check the condition of the mains plug and power cable. Do not under any circumstances use the device if you detect damages on the mains plug or power cable. If the power cable is damaged, it must be replaced by the manufacturer, its service agent or similarly qualified persons in order to avoid a hazard. Defective power cables pose a serious health risk!
- Before restarting the device, check the condition of the filter. If the filter is dirty or damaged, replace or clean it (see Replacing and/or cleaning the air filter in the Maintenance chapter).
- Insert the mains plug into a properly secured mains socket.

Connecting the power cable

Operation

- After being switched on, the device operates fully automatically.
- If the ventilation flip switch (24) is set to *Fan*, the fan runs continuously, even if the compressor is switched off. If the ventilation flip switch (24) is set to *Cycle*, the fan only runs if the compressor is running.
- If the device is equipped with a heating coil, the ventilation flip switch (24) must not be set to *Cycle*.
- Avoid open doors and windows.

Operating elements

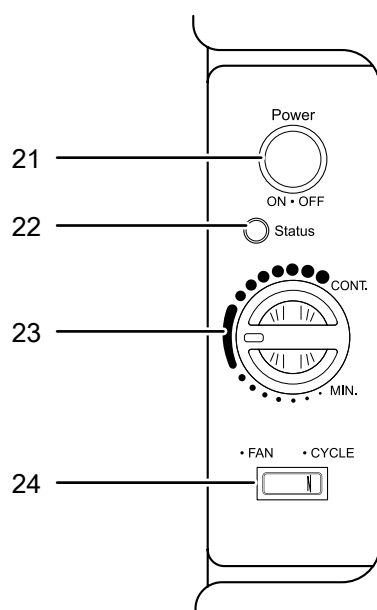

No.	Designation	Meaning
21	Power button	Switching the device on and off
22	Operating status light	Indicates if there is an error message (see Errors and faults chapter)
23	Hygrostat control dial	Setting the desired humidity level
24	Ventilation flip switch	Changing between the settings <i>Fan</i> (continuous ventilation operation) and <i>Cycle</i> (compressor-dependent ventilation operation)

Switching the device on

1. Press the power button (21).
⇒ The operating status light (22) flashes at regular intervals.

Regulating the humidity level

Set the desired humidity level via the hygrostat control dial (23). The horizontal position of the hygrostat control dial (23) is selected at the beginning and represents the basic setting (medium humidity value).

1. Turn the hygrostat control dial (23) counter-clockwise to increase the desired humidity level.
2. Turn the hygrostat control dial (23) clockwise to decrease the desired humidity level.

Operating the electric heater (DH 35 H / DH 65 H)

- ✓ The electric heater is installed at the factory as an option.
1. Remove the air inlet grille (5) from the device.

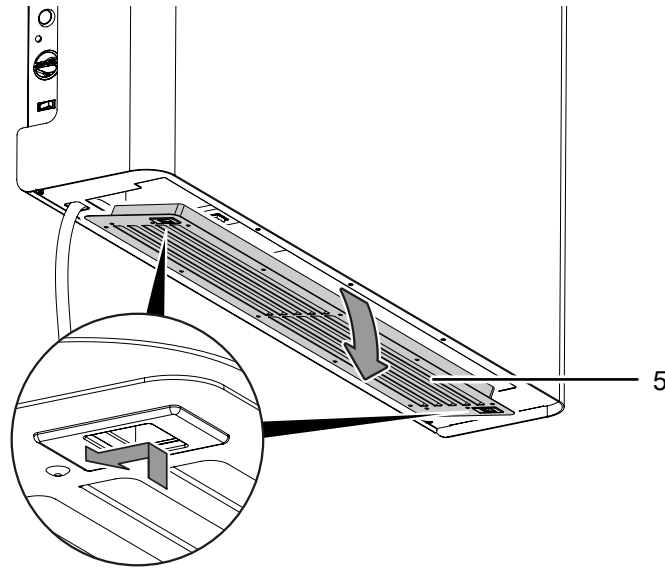

2. Set the desired temperature using the control dial (25).
3. Set the flip switch (26) to I to switch the electric heater on.

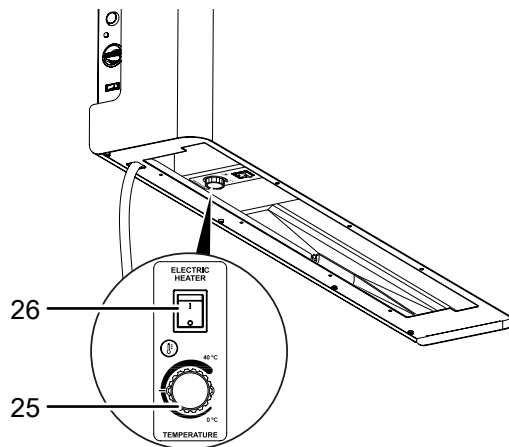

4. Refit the air inlet grille (5) into the device.

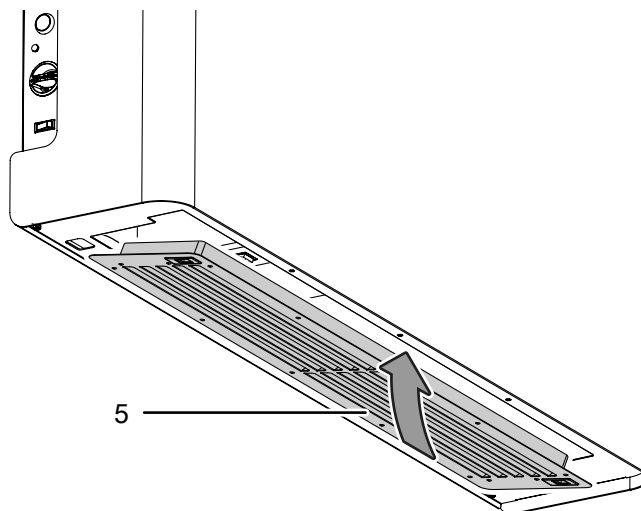

Errors and faults

The device has been checked for proper functioning several times during production. If malfunctions occur nonetheless, check the device according to the following list.

The device does not start:

- Check the power connection.
- Check the power cable for damages.
- Check the on-site fusing.
- Check the preselected humidity level at the hygostat's control dial. The humidity in the room must be above the selected range. Reduce the preselected desired humidity level.
- Have the electricians checked by a specialist company for cooling and air-conditioning or by the manufacturer.

The device is running, but there is no formation of condensate:

- Check the condensation hose for proper fit.
- Check the room temperature. Observe the device's permissible operating range according to the technical data.
- Check whether the actual humidity level is within the device's operating range (see Technical data).
- Check the preselected humidity level at the hygostat's control dial. The humidity level in the room where the device is positioned must be higher than the desired humidity level set. Reduce the preselected desired humidity level.

The device is loud or vibrates:

- Check whether the device is mounted horizontally.
- Check the inside of the device for dirt. Clean the interior of the device if necessary.

The device gets very warm, is loud or loses power:

- Check the air inlet and air filter for dirt. Remove external dirt.
- Check the inside of the device for dirt. Clean the interior of the device if necessary.

Your device still does not operate correctly after these checks?

Please contact the customer service. If necessary, bring the device to a specialist company for cooling and air-conditioning or to the manufacturer for repair.

Error messages

Under normal conditions, the operating status light (22) flashes slowly at regular intervals. The operating status light can indicate the following malfunctions of the device:

Status of the operating light	Cause	Remedy
Operating status light is permanently illuminated without flashing	NTC resistor and/or humidity sensor are defective	Switch the device off and contact the customer service.
Device is switched on and operating status light does not light up	Hardware fault	Switch the device off and contact the customer service.
Operating status light flashes quickly	Hygrostat is defective or timing next start (3 minutes)	Switch the device off and wait for 3 minutes. Switch the device back on. If the operating status light continues flashing, switch the device off again and contact the customer service.
Operating status light flashes irregularly	Ambient temperature is outside the permissible range	Switch off the device and make sure that the device is only operated within the permissible operating temperature range (see technical data and temperature operating range diagram).
	Pressure of the refrigerant circuit is outside the permissible range	Switch the device off and restart it. Should the problem persist, please contact the customer service.



Maintenance

Maintenance intervals

Maintenance and care interval	before every start-up	as needed	at least every 4 weeks	at least every 2 months	at least every 6 months	at least annually
Check air inlets and outlets for dirt and foreign objects and clean if necessary	X		X			
Clean the exterior		X				X
Visually inspect the inside of the device for dirt		X				X
Check for damage	X					X
Check the attachment screws		X				X
Test run						X
Replace the air filter					X	
Replace or wash the air filter (in case of a high dust and/or soot pollution)				X		
Empty the optional condensate pump, condensation tray and/or condenser dryer		X				

Maintenance and care log

Device type:

Device number:

Maintenance and care interval	1	2	3	4	5	6	7	8	9	10	11	12	13	14	15	16
Check air inlets and outlets for dirt and foreign objects and clean if necessary																
Clean the exterior																
Visually check the inside of the device for dirt																
Check for damage																
Check the attachment screws																
Replace or wash the air filter (in case of a high dust and/or soot pollution)																
Check the optional condensate pump and tank, and clean if necessary																
Test run																
Comments																

1. Date:	2. Date:	3. Date:	4. Date:
Signature:	Signature:	Signature:	Signature:
5. Date:	6. Date:	7. Date:	8. Date:
Signature:	Signature:	Signature:	Signature:
9. Date:	10. Date:	11. Date:	12. Date:
Signature:	Signature:	Signature:	Signature:
13. Date:	14. Date:	15. Date:	16. Date:
Signature:	Signature:	Signature:	Signature:

Activities required before starting maintenance



⚠ Warning of electrical voltage

Do not touch the mains plug with wet or damp hands.

- Disconnect the device from the mains by removing the mains plug from the socket. When doing so, be sure to hold the plug, not the cable.



⚠ Warning of electrical voltage

Maintenance tasks at the electrical equipment or the air-conditioning technology must only be carried out by specialist companies for cooling and air-conditioning or by the manufacturer.

en

Cleaning the housing

Clean the housing with a soft, damp and lint-free cloth. Make sure that no moisture enters the housing. Protect electrical components from moisture. Do not use any aggressive cleaning agents such as cleaning sprays, solvents, alcohol-based or abrasive cleaners to dampen the cloth.

Visual inspection of the inside of the device for dirt

1. Remove the air filter.
2. Use a torch to illuminate the openings of the device.
3. Check the inside of the device for dirt.
4. Put the air filter back in.

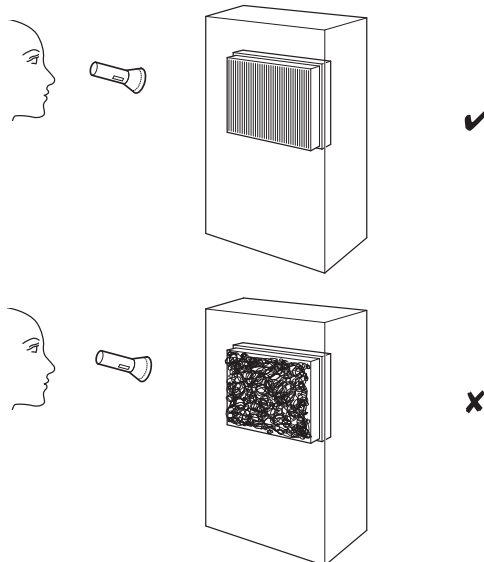

Refrigerant circuit

DH 20



Danger

Natural refrigerant propane (R290)!

H220 – Extremely flammable gas.

H280 – Contains gas under pressure; may explode if heated.

P210 – Keep away from heat, sparks, open flames and other ignition sources. No smoking.

P377 – Leaking gas fire: Do not extinguish, unless leak can be stopped safely.

P410+P403 – Protect from sunlight. Store in a well-ventilated place.

DH 35 / DH 35 H /
DH 65 / DH 65 H



Danger

Refrigerant R454C

H221 – Flammable gas.

H280 – Contains gas under pressure; may explode if heated.

P210 – Keep away from heat, sparks, open flames and other ignition sources. No smoking.

P377 – Leaking gas fire; Do not extinguish, unless leak can be stopped safely.

P381 – Eliminate all ignition sources if safe to do so.

P410 and P403 – Protect from sunlight. Store in a well-ventilated place.

- The entire refrigerant circuit is a maintenance-free, hermetically sealed system and may only be maintained or repaired by specialist companies for cooling and air-conditioning or by the manufacturer.

Replacing and/or cleaning the air filter

Perform this activity every 6 months. In case of a high dust and/or soot pollution, clean or wash the air filter after 2 months.

Notice

Make sure that the air filter is not damaged.

The air filter must be dry after cleaning before being reinserted.

Notice

Do not operate the device without an air filter inserted into the air inlet!

Without the air filter, the inside of the device will be heavily contaminated. This will reduce the performance and result in damage to the device.

The air filter is installed upon delivery. Please proceed as follows to replace or wash the air filter:

1. Remove the air inlet grille (5) from the device.

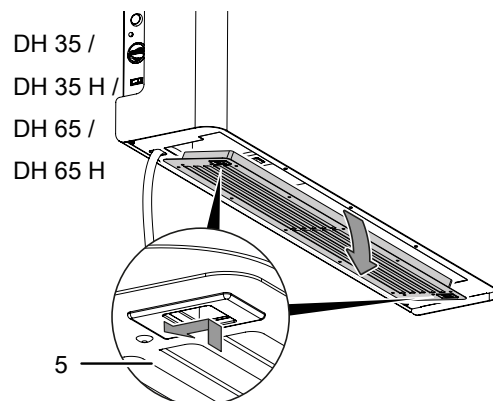
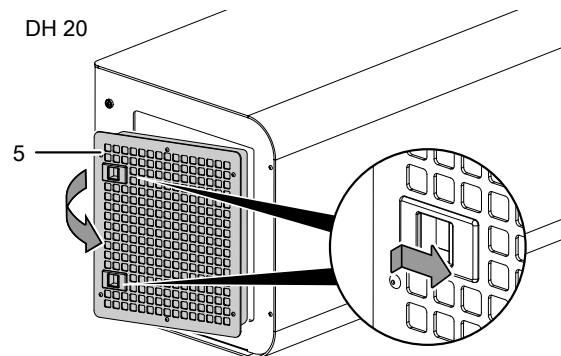

2. Remove the retaining bracket (28) and then remove the air filter (27).

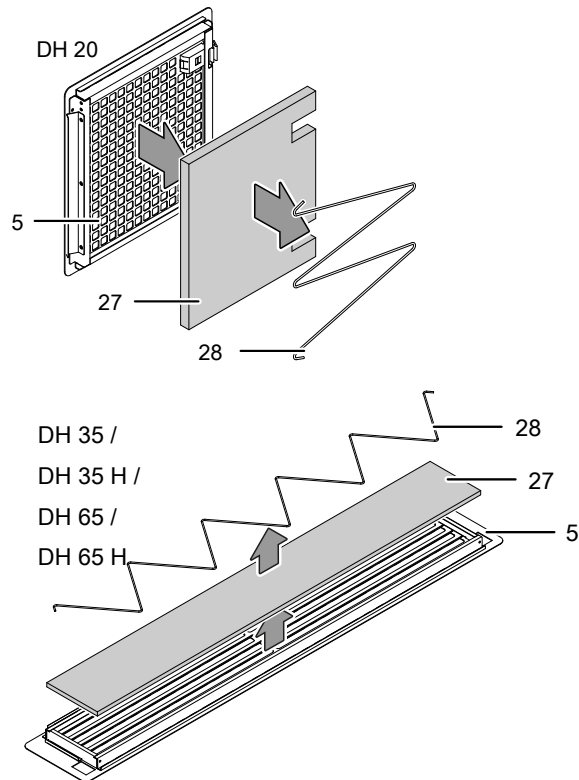

3. **If the air filter is slightly dirty:** Rinse the air filter (27) under running water and clean it with a dry cloth.
4. **If the air filter is damaged or heavily contaminated:** Dispose of the old air filter according to the national regulations.
5. Insert the washed or new air filter (27) into the air inlet grille (5) and secure it with the retaining bracket (28).

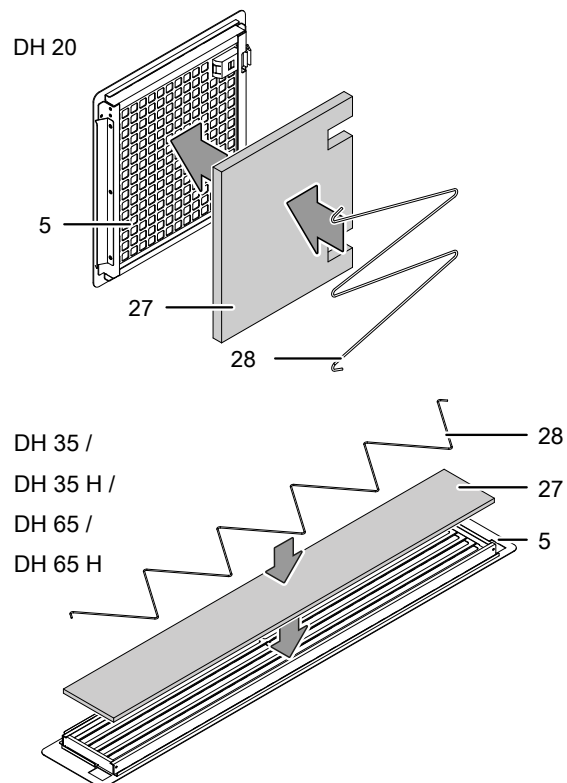

6. Insert the air inlet grille (5) with the air filter (27) into the device.

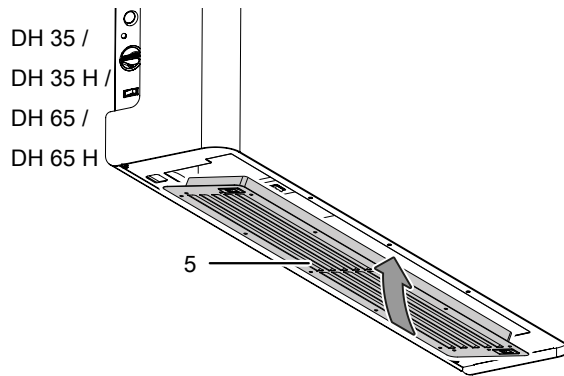
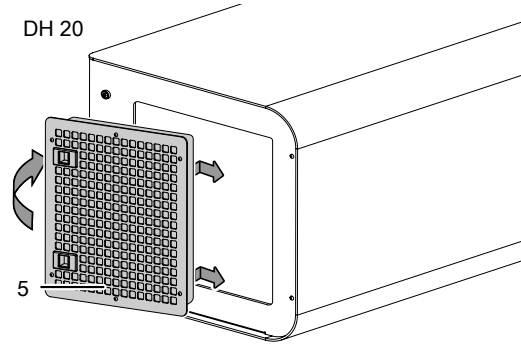

Technical annex

Technical data

Parameter	DH 20	DH 35	DH 35 H (with electric heater)	DH 65	DH 65 H (with electric heater)
Dehumidification performance	see dehumidification chart and diagrams on capacity, specific power and energy factor				
Mains connection	220–240 V ~50 Hz	220–240 V ~50 Hz	220–240 V ~50 Hz	220–240 V ~50 Hz	220–240 V ~50 Hz
Max. power input	0.507 kW	0.950 kW	2.950 kW	1.157 kW	4.657 kW
Heating capacity (with electric heater) @ 230 V	n/a	n/a	2.000 kW	n/a	3.500 kW
Refrigerant	R290	R-454C	R-454C	R-454C	R-454C
GWP factor	3	146	146	146	146
CO ₂ equivalent	0.0005 t	0.073 t	0.073 t	0.124 t	0.124 t
Amount of refrigerant	150 g	500 g	500 g	850 g	850 g
Suction side pressure	0.2 MPa	0.6 MPa	0.6 MPa	0.6 MPa	0.6 MPa
Discharge side pressure	1.6 MPa	2.3 MPa	2.3 MPa	2.3 MPa	2.3 MPa
Max. pressure	3.0 MPa	3.0 MPa	3.0 MPa	3.0 MPa	3.0 MPa
Air volume (freely blowing)	375 m ³ /h	500 m ³ /h	500 m ³ /h	800 m ³ /h	800 m ³ /h
Sound pressure level @ 1 m	51 dB(A)	49 dB(A)	49 dB(A)	48 dB(A)	48 dB(A)
Operating range temperature	5 °C to 40 °C (see temperature operating range diagram)	5 °C to 40 °C (see temperature operating range diagram)	5 °C to 40 °C (see temperature operating range diagram)	5 °C to 40 °C (see temperature operating range diagram)	5 °C to 40 °C (see temperature operating range diagram)
Setting range relative humidity	40 % RH to 80 % RH	40 % RH to 80 % RH	40 % RH to 80 % RH	40 % RH to 80 % RH	40 % RH to 80 % RH
Max. permissible relative humidity	90 % RH	90 % RH	90 % RH	90 % RH	90 % RH
Weight	33 kg	50 kg	52 kg	76 kg	78 kg
Dimensions (length x width x height)	900 x 350 x 365 mm	885 x 265 x 720 mm	885 x 265 x 720 mm	1306 x 265 x 720 mm	1306 x 265 x 720 mm
Connection of condensation hose (diameter)	16 mm	16 mm	16 mm	16 mm	16 mm
Type of protection	IPX2	IPX2	IPX2	IPX2	IPX2
Optional hot water heating coil	n/a	1.9 kW	n/a	3.8 kW	n/a
Heating capacity at a hot water temperature of 55 °C/50 °C and 29 °C air temperature					
Heating capacity at a hot water temperature of 80 °C/70 °C and 29 °C air temperature		3.8 kW		7.5 kW	
Water flow rate		5 l/m		11.7 l/m	
Pipe connection size (diameter)		15 mm		15 mm	
Pressure loss		3.5 kPa		17.3 kPa	
Minimum distance to walls or other objects:					
A: top:	30 cm	30 cm	30 cm	30 cm	30 cm
B: bottom:	30 cm	30 cm	30 cm	30 cm	30 cm
C: side:	50 cm	20 cm	20 cm	20 cm	20 cm
D: front:	50 cm	50 cm	50 cm	50 cm	50 cm

n/a = not specified

**Capacity and specific power
DH 20**

Ambient conditions	Capacity	Power consumption	Nominal current	Energy consumption
10 °C / 80 % RH	7.2 l/24 h	0.386 kW	2.5 A	1.278 kWh/l
20 °C / 60 % RH	12.6 l/24 h	0.434 kW	2.5 A	0.824 kWh/l
30 °C / 60 % RH	18.4 l/24 h	0.507 kW	2.8 A	0.661 kWh/l

**Capacity and specific power
DH 35 / DH 35 H***

Ambient conditions	Capacity	Power consumption	Nominal current	Energy consumption
10 °C / 80 % RH	11.7 l/24 h	0.552 kW	2.5 A	1.134 kWh/l
20 °C / 60 % RH	20.2 l/24 h	0.695 kW	3.2 A	0.827 kWh/l
30 °C / 60 % RH	29.3 l/24 h	0.876 kW	4.0 A	0.718 kWh/l
30 °C / 80 % RH	40.4 l/24 h	0.950 kW	4.3 A	0.564 kWh/l

* except the optional heating coil

**Capacity and specific power
DH 65 / DH 65 H***

Ambient conditions	Capacity	Power consumption	Nominal current	Energy consumption
10 °C / 80 % RH	21.3 l/24 h	0.721 kW	3.3 A	0.814 kWh/l
20 °C / 60 % RH	29.0 l/24 h	0.864 kW	3.9 A	0.716 kWh/l
30 °C / 60 % RH	41.6 l/24 h	1.086 kW	4.9 A	0.626 kWh/l
30 °C / 80 % RH	58.3 l/24 h	1.157 kW	5.3 A	0.476 kWh/l

* except the optional heating coil

Condensation principle illustration

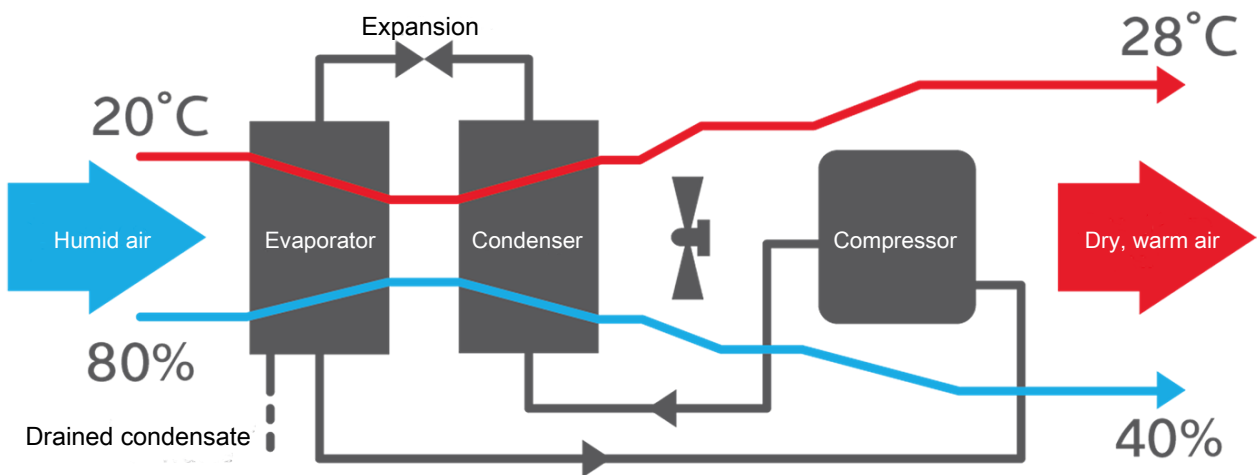

**Temperature
operating range
DH 20 / DH 35 /
DH 35 H / DH 65 /
DH 65 H**

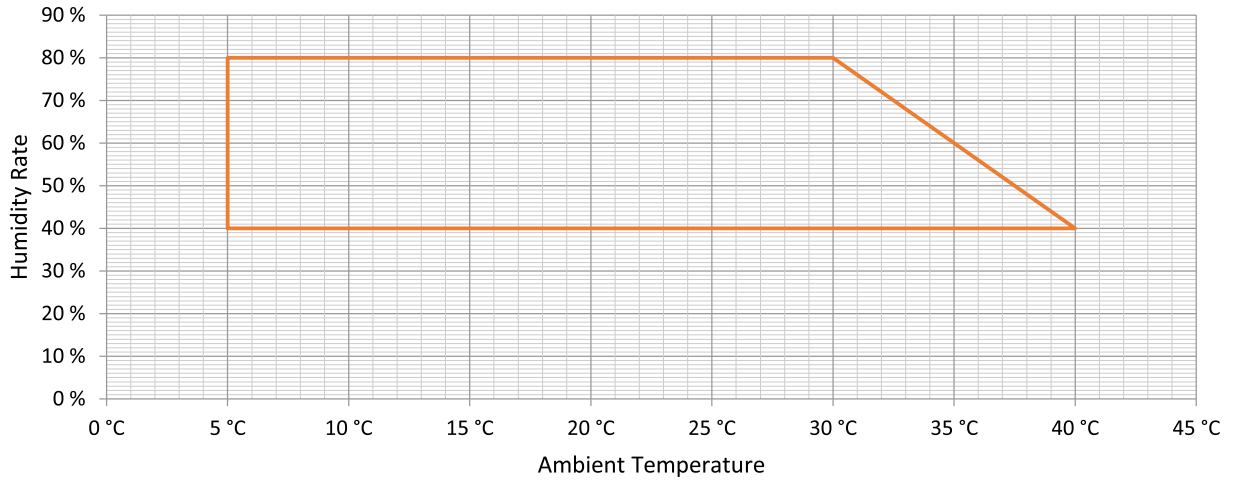

**Dehumidification
performance of
the DH 20**

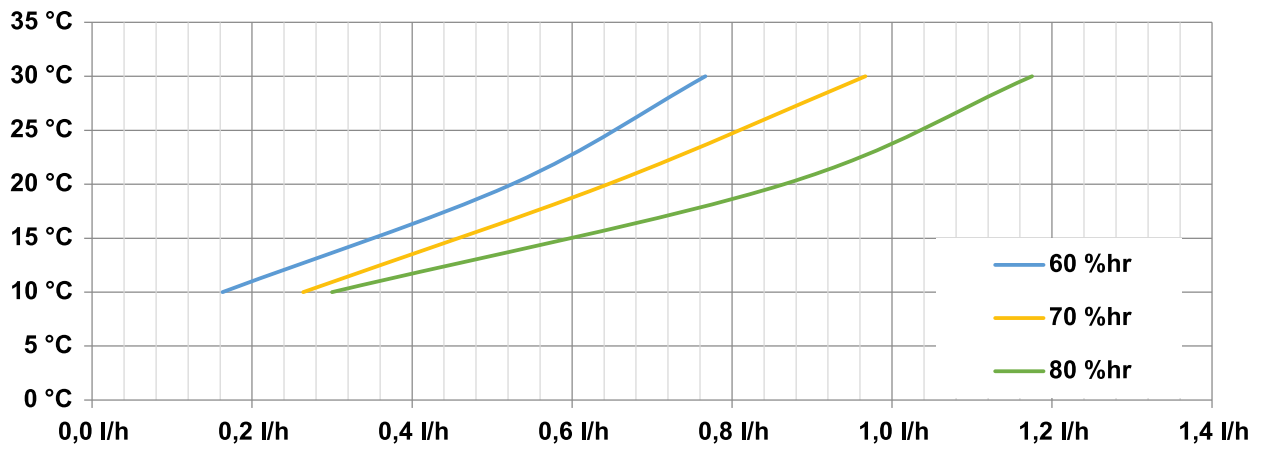

**Dehumidification performance
DH 35 / DH 35 H**

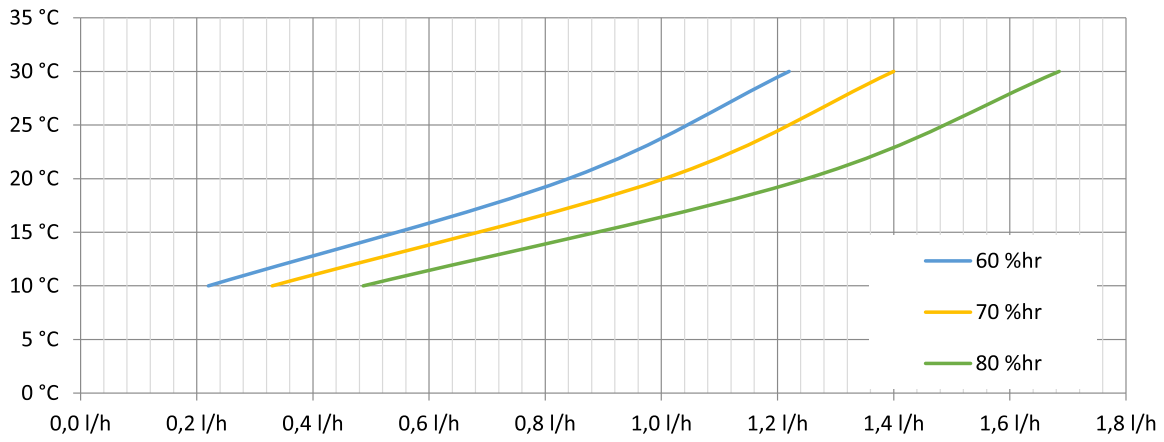

**Dehumidification performance
DH 65 / DH 65 H**

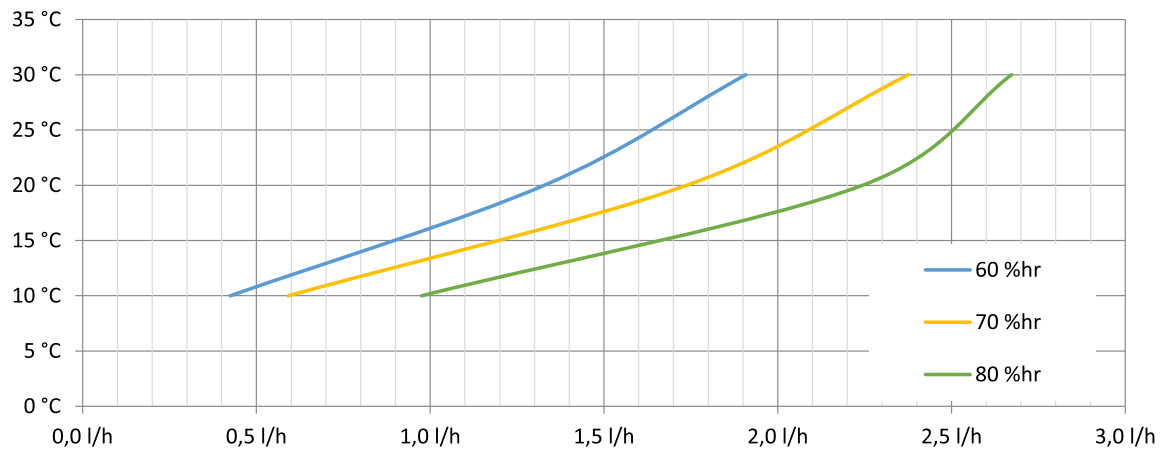

Energy factor DH 20

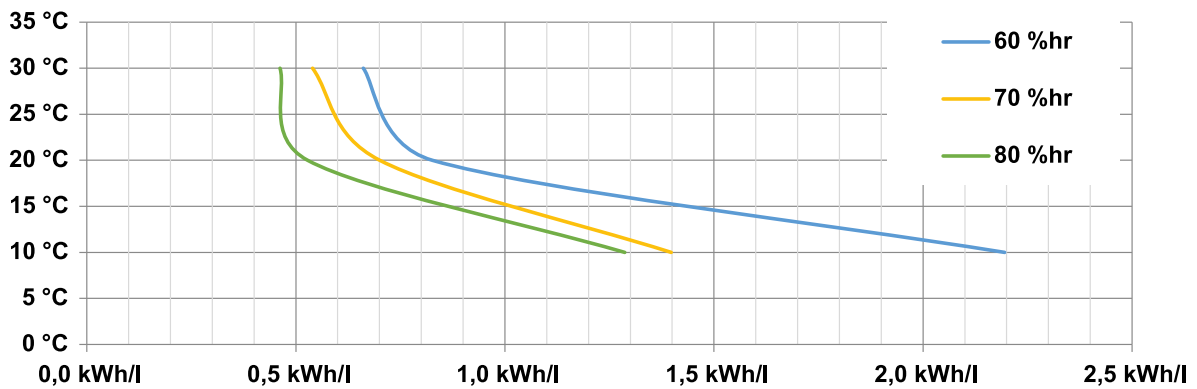

**Energy factor
DH 35 / DH 35 H***

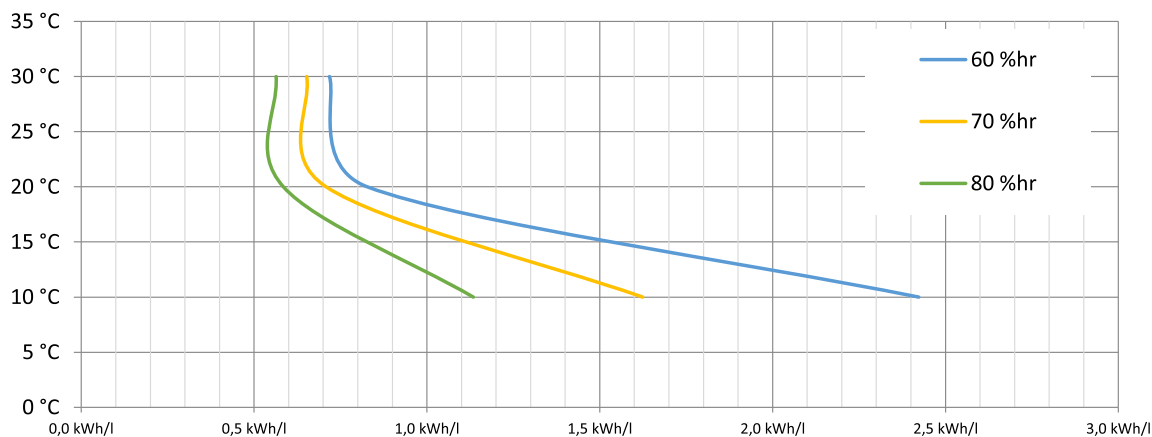

* except the optional heating coil

**Energy factor
DH 65 / DH 65 H***

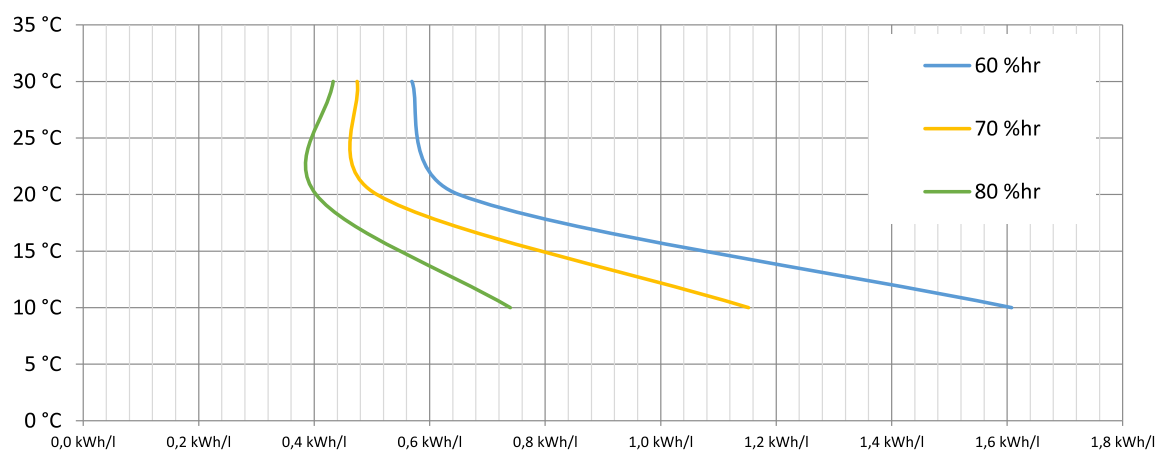

* except the optional heating coil

**Installing the
heating coil
(optional for
DH 35 and DH 65)**

Notice

A separate heating coil can be ordered as an option for the DH 35 and DH 65. The heating coil is not included in the standard scope of delivery. The heating coil may only be installed by a plumber. Please observe the supplied installation instructions for the heating coil.

Please proceed as follows to install the heating coil:

- ✓ The device is switched off and not connected to the mains.

1. Loosen the screws at the bottom of the housing and remove the housing (1).

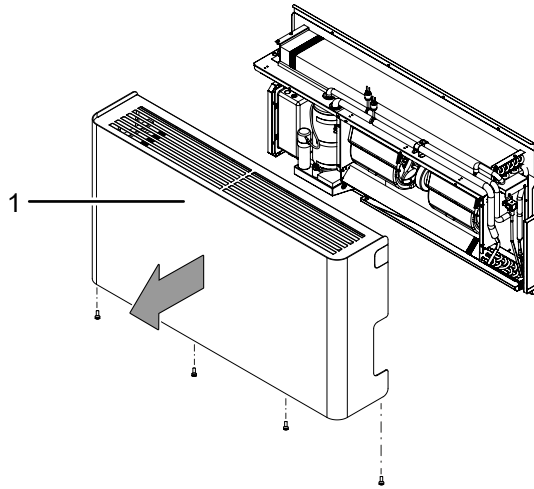

2. Place the heating coil (29) on top of the condenser and fasten it with the screws provided. The heating coil can be installed in both directions.

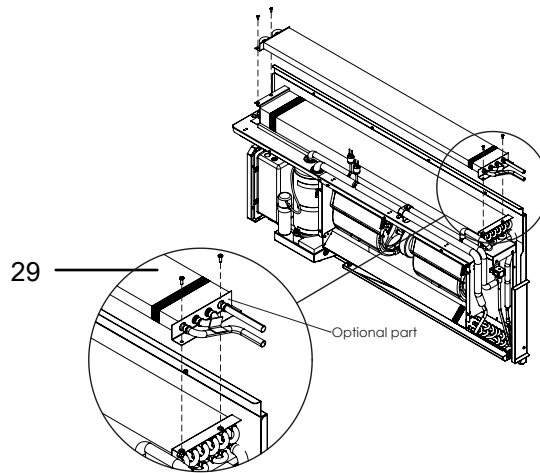

3. Install the piping for the heating coil (29).

4. Break out the designated recess in the housing and cut the insulation to size.

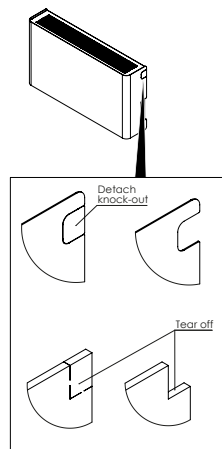

5. Reattach the housing (1) and tighten all screws.

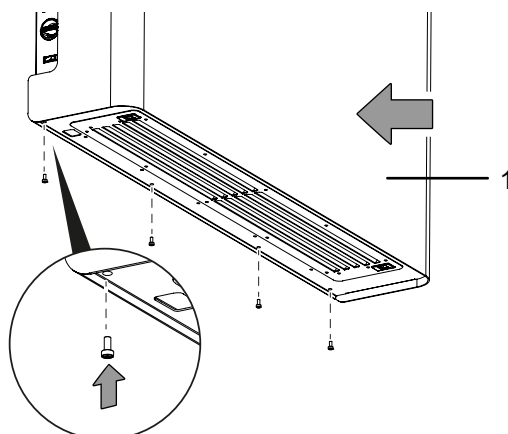

Connecting a remote control with on/off switch (optional for DH 35, DH 35 H, DH 65 and DH 65 H)

You have the option of connecting a wired remote control to the DH 35 or DH 65. The wired remote control and the two-core cable are not included in the scope of delivery and must be purchased separately. Observe the country-specific regulations and the Technical data in the annex when purchasing the remote control. The remote control must be connected by a qualified electrician.

Please proceed as follows to connect the remote control:

- ✓ **If the device has already been used:** Make sure that the device is switched off and that the mains plug has been disconnected from the socket.

1. Loosen the screws at the housing (1) and remove the housing.

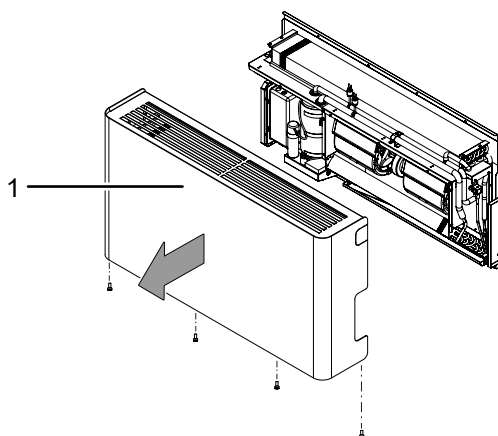

2. Loosen the screws on the switch box cover (30) and remove the cover.

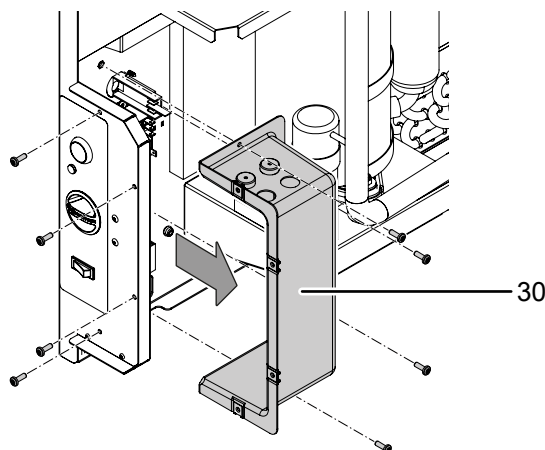

3. The connection is located in the top left corner. Remove the jumper (31) at the connection for the remote control (32). The jumper is no longer needed.

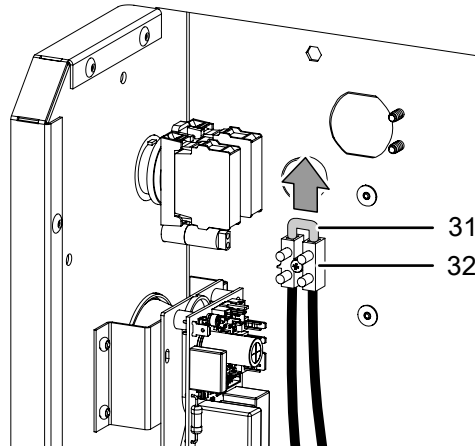

4. Feed the two-core cable of the remote control unit (on-site) through the hole (8) in the rear panel of the device from the outside.
5. Connect the two-core cable to the connection (32).

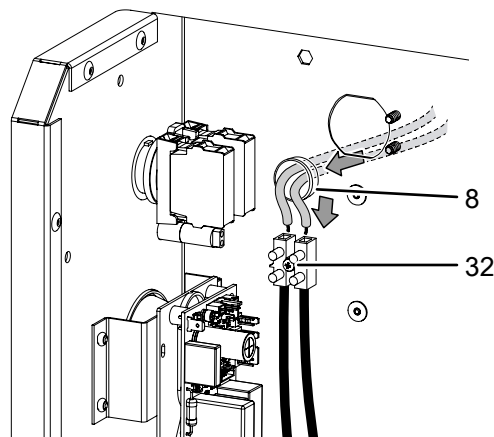

6. Reattach the switch box cover (30) and secure it with the screws.

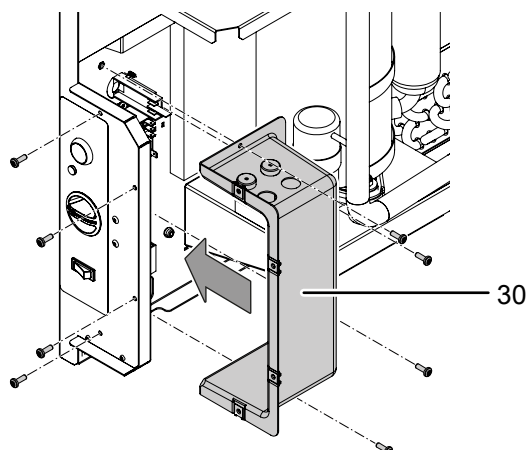

7. Reattach the housing (1) and tighten the screws.

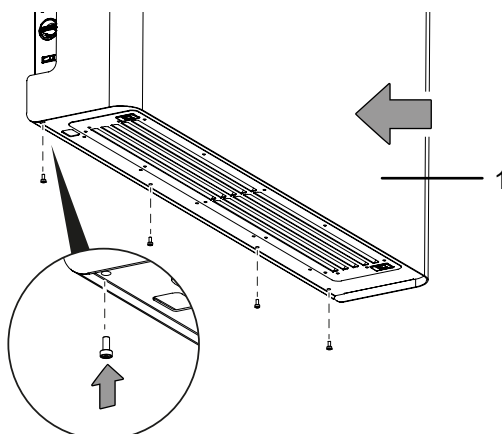

Wiring diagram
DH 20

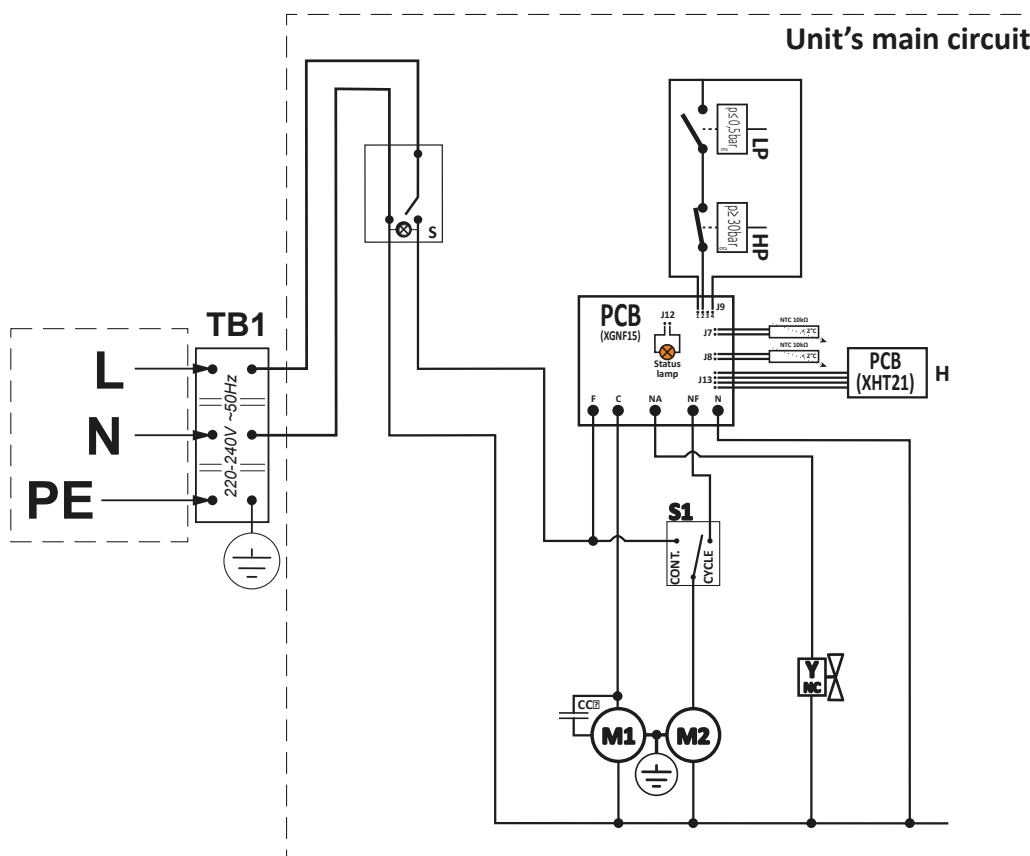

L – Protective Earth	CCR – Running capacitor
N – Common Line	M2 – Fan motor
PE – Protective Earth	SF – Fan mode switch
TB1 – Terminal blocks	HP – High pressure switch (NC)
VT – Power supply 12 Vac	LP – Low pressure switch (NO)
S – On-Off switch 0/1	Y – Defrost solenoid valve (NC)
M1 – Compressor	H – Electronic humidistat

Wiring diagram
DH 35 / DH 65

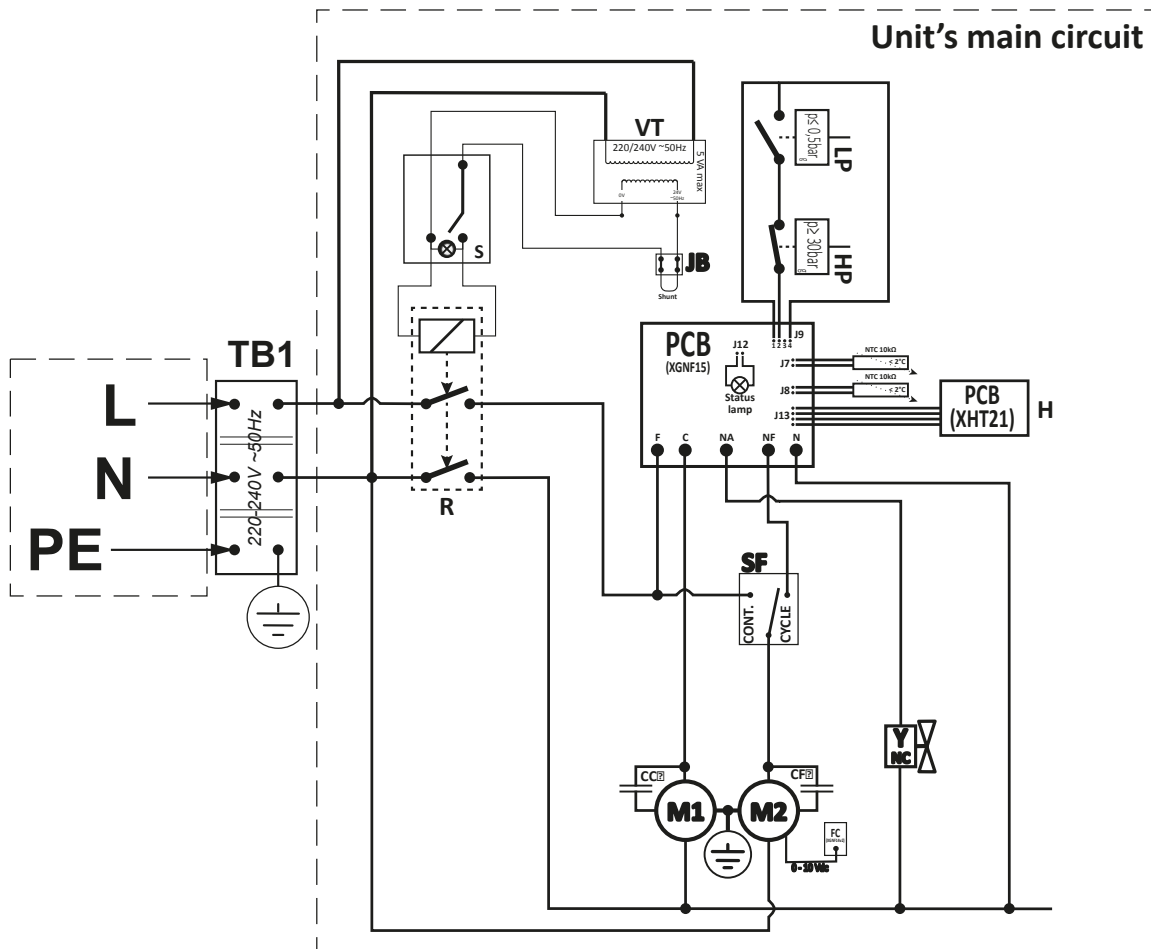

NOTE: Power cord (minimum cross section of sheathed cord is H05RNF 3G 1,5 mm²) not included in the scope of the package - type Y attachment;

L – Protective Earth	CCR – Running capacitor
N – Common Line	M2 – Fan motor
PE – Line	CFR – Running capacitor (only in DH 35)
TB1 – Terminal blocks	SF – Fan mode switch
VT – Power supply 12 VAC	FC – Fan control (only in DH 65)
JB – Junction bar (for remote On-Off switch)	HP – High pressure switch (NC)
R – Power relay	LP – Low pressure switch (NO)
S – On-Off switch 0/1	Y – Two way valve
M1 – Compressor	H – Electronic humidistat

**Wiring diagram
DH 35 H / DH 65 H
(with electric
heating option)**

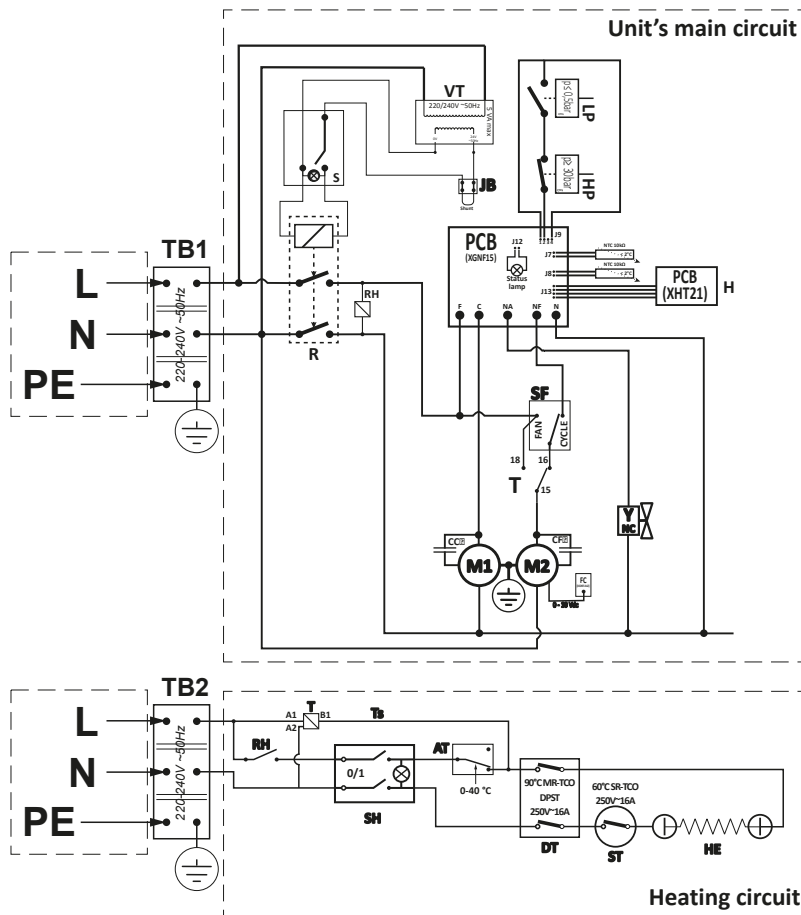

NOTE: Power cords (minimum cross section of sheathed cords for each circuit is H05RNF 3G 1,5 mm²) not included in the package - type Y attachment;

L – Protective Earth	FC – Fan control (only in DH 65)
N – Common Line	HP – High pressure switch (NC)
PE – Line	LP – Low pressure switch (NO)
TB1/2 – Terminal blocks	Y – Two way valve
VT – Power supply 12 VAC	H – Electronic humidistat
JB – Junction bar (for remote On-Off switch)	RH – Circuit break relay
R – Power relay	SH – Heating switch
S – On-Off switch 0/1	HE – Heating element
M1 – Compressor	T – Timer switch
CCR – Running capacitor	TS – Fan overrun contact 2'
M2 – Fan motor	AT – Ambient thermostat'
CFR – Running capacitor (only in DH 35)	AT – Safety thermostat
SF – Fan mode switch	DT – Safety thermostat MR-DPST

**Exploded assembly
drawing DH 20**



Info

The position numbers of the spare parts differ from those describing the positions of the components mentioned in these instructions.

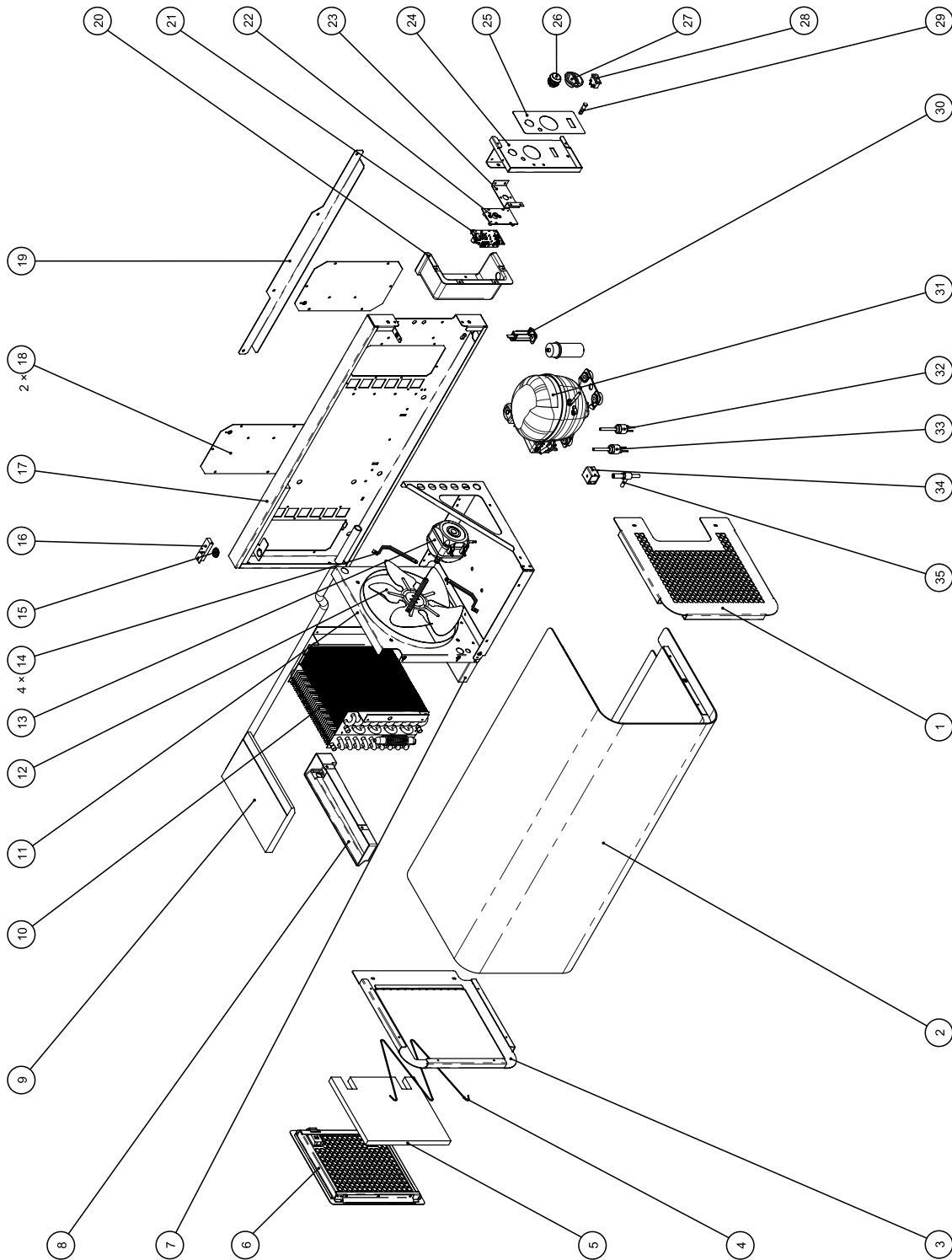

No.	Spare part	Quantity	No.	Spare part	Quantity
1	Outlet air panel	1	19	Wall bracket	1
2	Housing	1	20	Control panel cover	1
3	Air inlet panel	1	21	Electronic controller	1
4	Air filter bracket	1	22	Electronic controller bracket	1
5	Air filter	1	23	Electronic controller support	1
6	Air inlet grille	1	24	Control panel frame	1
7	Cooling system deck	1	25	Control panel sticker	1
8	Water Pan	1	26	On/Off switch	1
9	Insulating EPS	1	27	Humidistat knob	1
10	Heat exchangers	1	28	Fan/Cycle modes' switch	1
11	Ventilation shield	1	29	Electronic controller status LED	1
12	Fan blade	1	30	Cable gland with electric terminal block	1
13	Fan motor	1	31	Compressor	1
14	Fan brackets	4	32	Low pressure switch	1
15	Humidity sensor case	1	33	High pressure switch	1
16	Humidity sensor	1	34	Defrost valve coil	1
17	Back frame	1	35	Defrost valve	1
18	Duct cover	2			

Exploded assembly drawing DH 35 (with optional heating coil)



Info

The position numbers of the spare parts differ from those describing the positions of the components mentioned in these instructions.

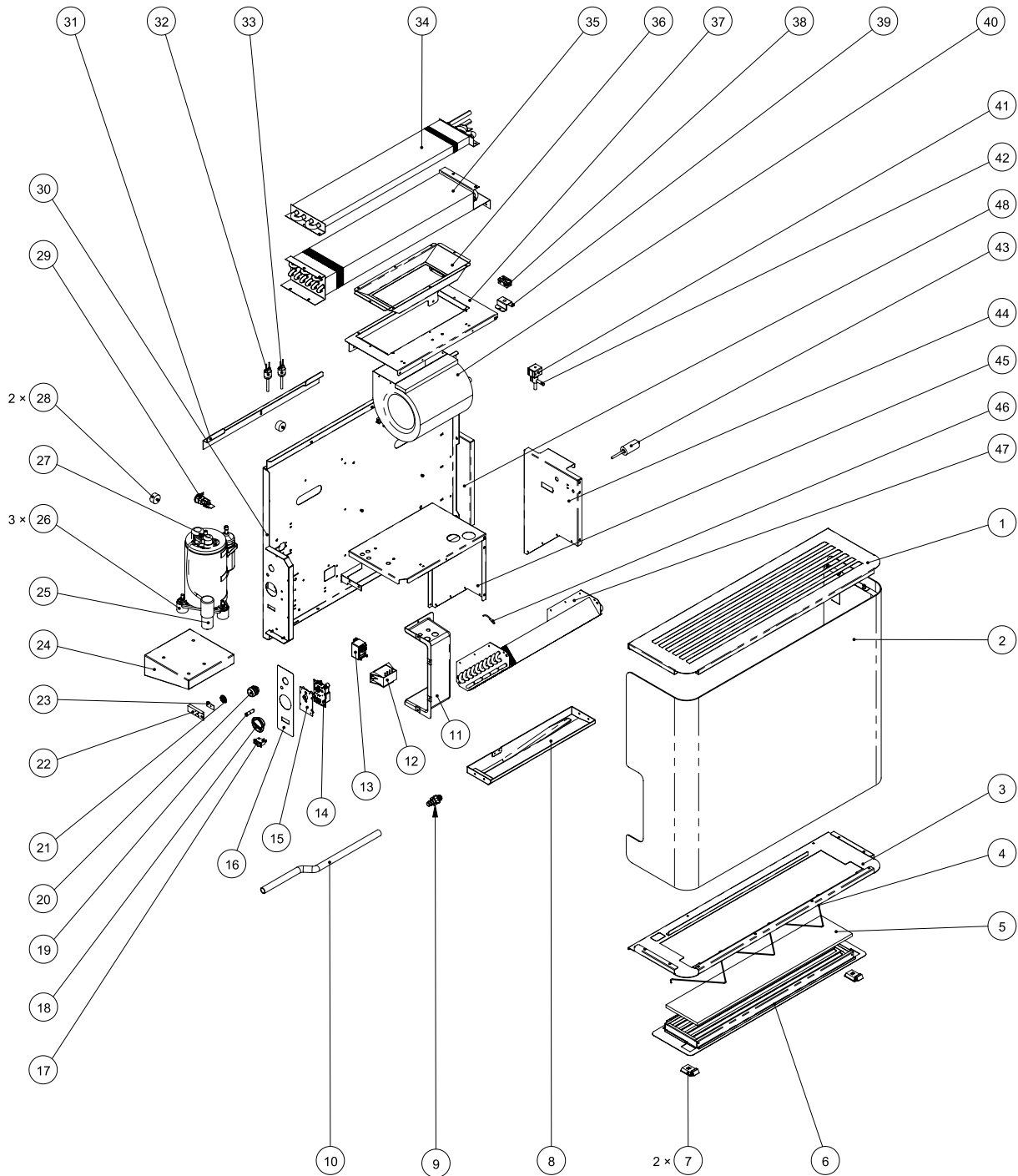

No.	Spare part	Quantity	No.	Spare part	Quantity
1	Air outlet grille	1	25	Compressor's capacitor	1
2	Housing	8	26	Compressor grommet	3
3	Air inlet grille support panel	1	27	Compressor	1
4	Air filter bracket	1	28	Tilt wall spacer	2
5	Air filter	1	29	Cable gland with electrical terminal block	1
6	Air inlet grille	1	30	Frame's back plate	1
7	Snap-lock	2	31	Wall bracket	1
8	Water pan	1	32	Low pressure switch	1
9	Hose fitting	1	33	High pressure switch	1
10	Draining hose	1	34	LPHW coil (option)	1
11	Control panel lid	1	35	Condensing coil	1
12	SELV voltage transformer - for remote switch option	1	36	Fan plenum	1
13	Power relays	1	37	Fan baseplate	1
14	Electronic controller	1	38	Pipe clamp	1
15	Electronic controller bracket	1	39	Pipe clamp bracket	1
16	Control panel sticker	1	40	Fan	1
17	Fan/Cycle modes' switch	1	41	Defrost valve coil	1
18	Humidistat knob	1	42	Defrost valve	1
19	Electronic controller status LED	1	43	Fan's capacitor	1
20	On/Off switch	1	44	Chassis left panel	1
21	Humidity sensor vent	1	45	Chassis right panel	1
22	Humidity sensor lid	1	46	Defrost sensor	1
23	Humidity sensor	1	47	Evaporating coil	1
24	Compressor baseplate	1			1

Exploded assembly drawing DH 35 (interior view with optional heating coil)



Info

The position numbers of the spare parts differ from those describing the positions of the components mentioned in these instructions.

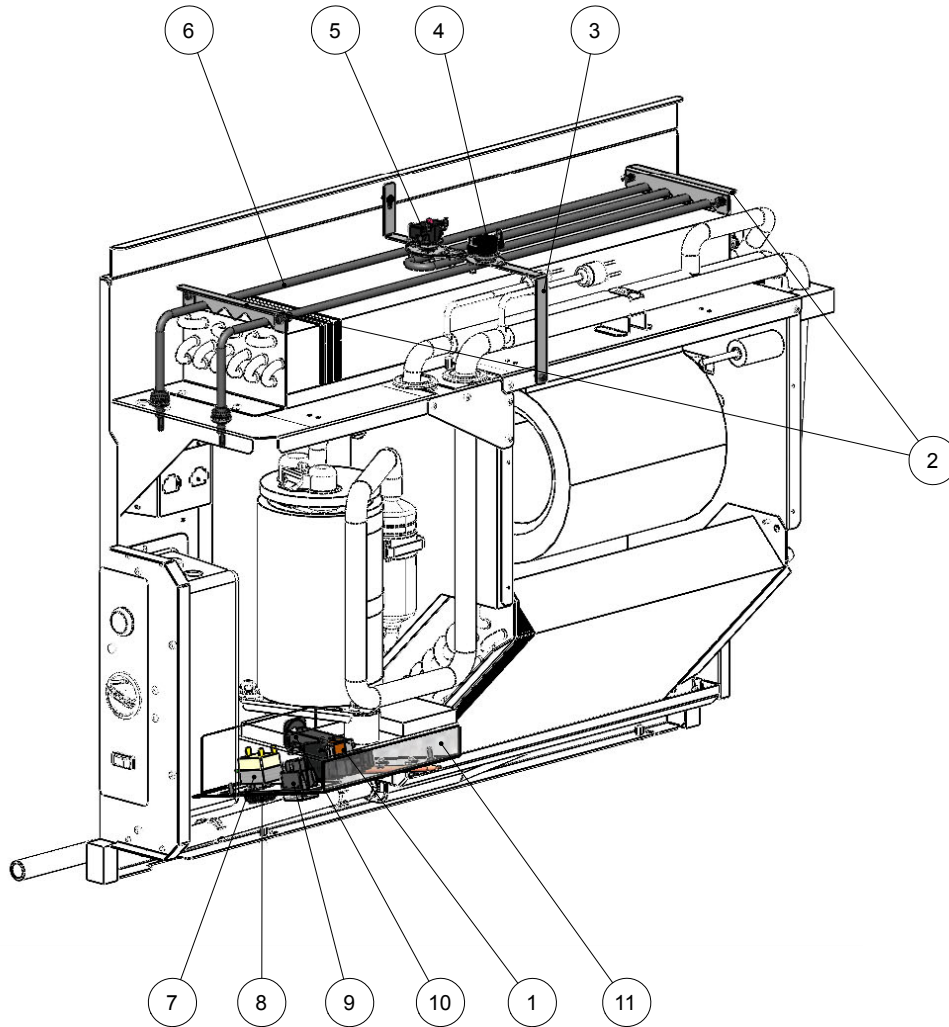

No.	Spare part	Quantity	No.	Spare part	Quantity
1	Heating element relays	1	7	Ambient thermostat	1
2	End plate brackets	2	8	Humidistat knob	1
3	Heating element brackets	1	9	Heating circuit switch	1
4	Automatic reset	1	10	Cable gland with electric terminal block	1
5	Manual self - resetting thermal cut-out	1	11	Dashboard (exclusive for heating option)	1
6	Heating element	1			

**Exploded
assembly drawing
DH 65 (with
optional heating
coil)**



Info

The position numbers of the spare parts differ from those describing the positions of the components mentioned in these instructions.

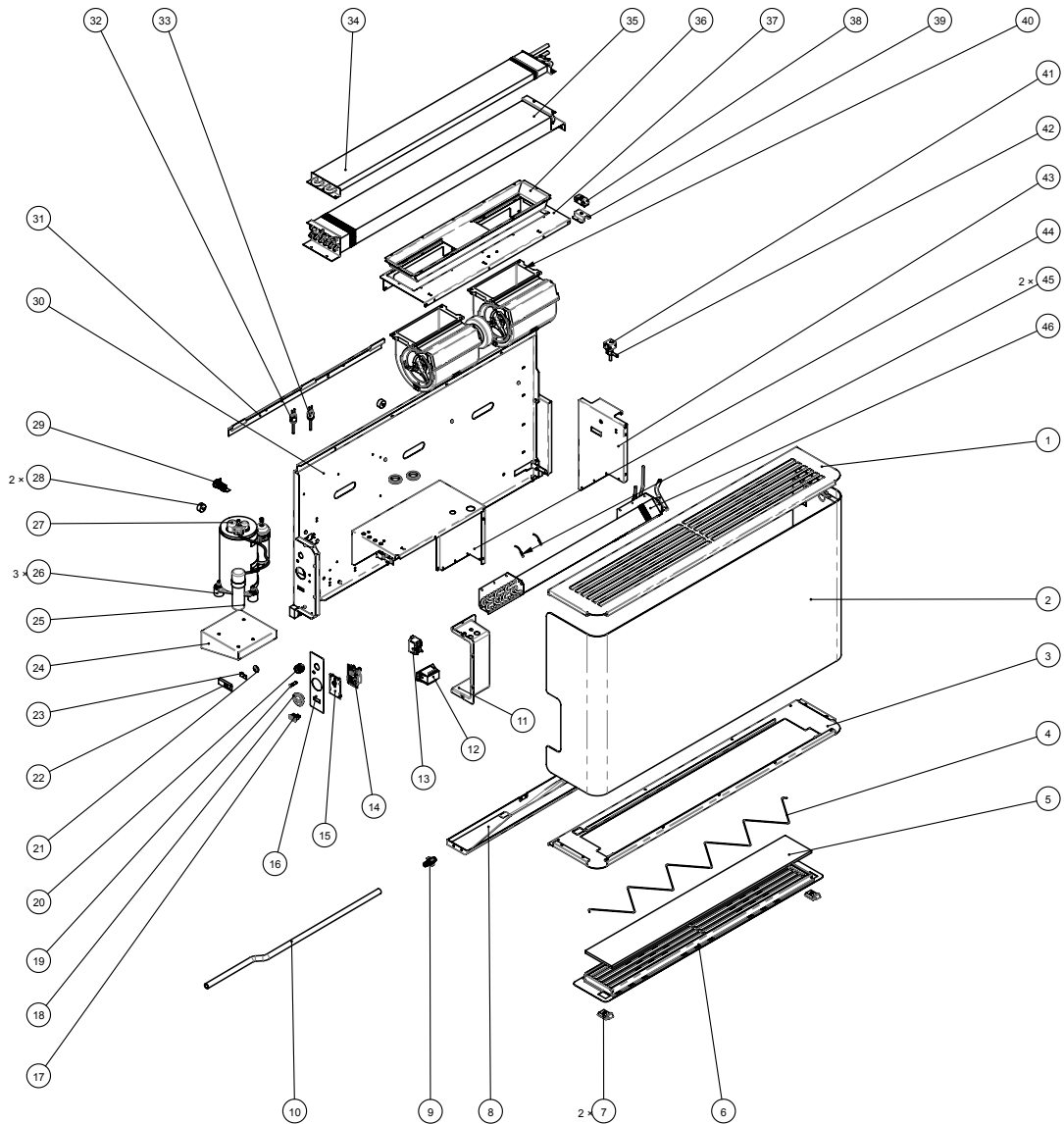

No.	Spare part	Quantity	No.	Spare part	Quantity
1	Air outlet grille	1	25	Compressor's capacitor	1
2	Housing	1	26	Compressor grommet	3
3	Air inlet grille support panel	1	27	Compressor	1
4	Air filter bracket	1	28	Tilt wall spacer	2
5	Air filter	1	29	Cable gland with electrical terminal block	1
6	Air inlet grille	1	30	Frame's back plate	1
7	Snap-lock	2	31	Wall bracket	1
8	Water pan	1	32	Low pressure switch	1
9	Hose fitting	1	33	High pressure switch	1
10	Draining hose	1	34	LPHW coil (option)	1
11	Control panel lid	1	35	Condensing coil	1
12	SELV voltage transformer - for remote switch option	1	36	Fan plenum	1
13	Power relays	1	37	Fan baseplate	1
14	Electronic controller	1	38	Pipe clamp	1
15	Electronic controller bracket	1	39	Pipe clamp bracket	1
16	Control panel sticker	1	40	Fan	1
17	Fan/Cycle modes' switch	1	41	Defrost valve coil	1
18	Humidistat knob	1	42	Defrost valve	1
19	Electronic controller status LED	1	43	Chassis left panel	1
20	On/Off switch	1	44	Chassis right panel	2
21	Humidity sensor vent	1	45	Defrost sensor	2
22	Humidity sensor lid	1	46	Evaporating coil	1
23	Humidity sensor	1			
24	Compressor baseplate	1			

**Exploded
assembly drawing
DH 65 (interior
view with
optional heating
coil)**



Info

The position numbers of the spare parts differ from those describing the positions of the components mentioned in these instructions.

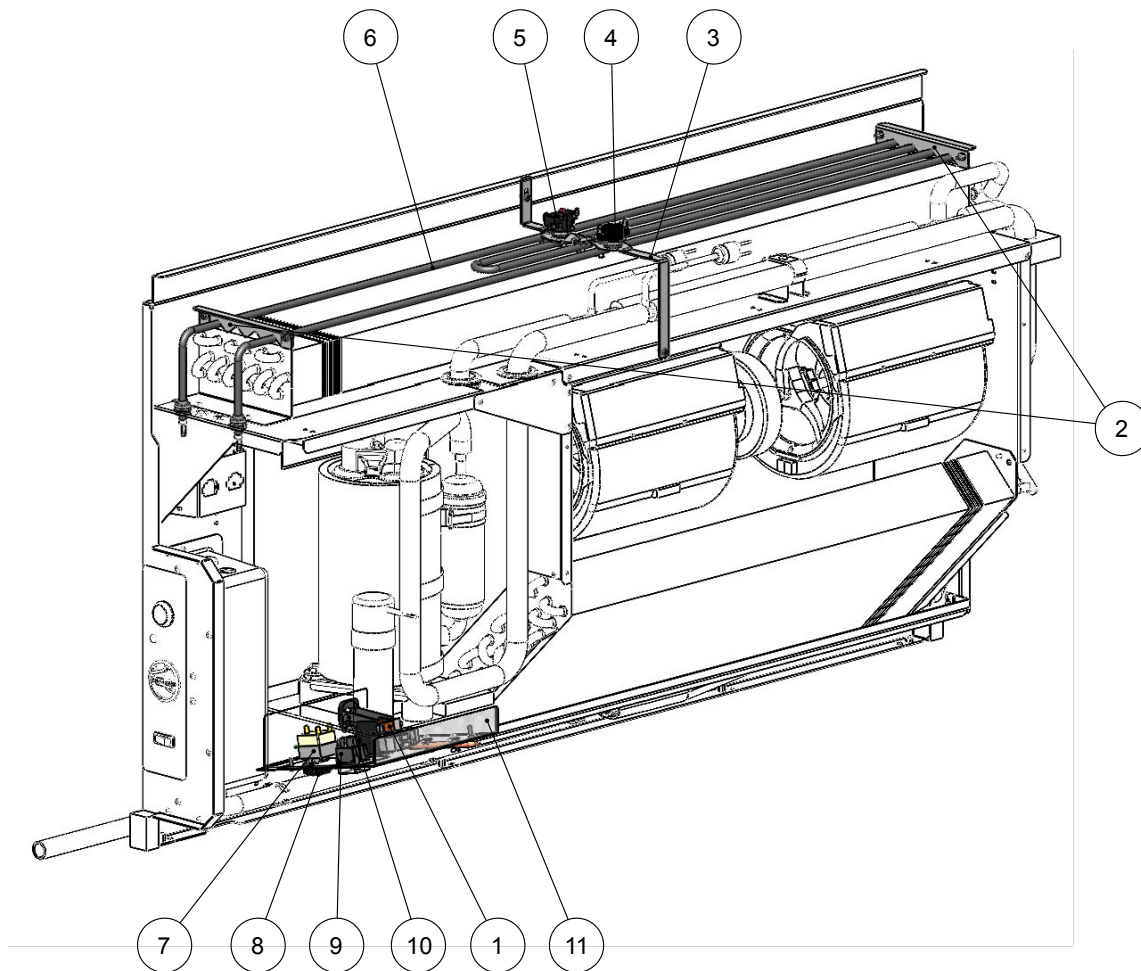

No.	Spare part	Quantity	No.	Spare part	Quantity
1	Heating element relays	1	7	Ambient thermostat	1
2	End plate brackets	2	8	Humidistat knob	1
3	Heating element brackets	1	9	Heating circuit switch	1
4	Automatic reset	1	10	Cable gland with electric terminal block	1
5	Manual self - resetting thermal cut-out	1	11	Dashboard (exclusive for heating option)	1
6	Heating element				

Disposal

Always dispose of packing materials in an environmentally friendly manner and in accordance with the applicable local disposal regulations.



The icon with the crossed-out wheeled bin indicates that this device and any associated components must not be disposed of with household waste at the end of their life, in accordance with the Waste Electrical and Electronic Equipment Directive (2012/19/EU) and national laws.

You will find collection points for free return of waste electrical and electronic equipment in your vicinity. The addresses can be obtained from your municipality or local administration. You can also find out about other return options that apply for many EU countries on the website <https://hub.trotec.com/?id=45090>. Otherwise, please contact an official recycling centre for electronic and electrical equipment authorised for your country.

The separate collection of waste electrical and electronic equipment aims to enable the re-use, recycling and other forms of recovery of waste equipment as well as to prevent negative effects for the environment and human health caused by the disposal of hazardous substances potentially contained in the equipment.

Have the refrigerant (propane) disposed of appropriately and according to the national regulations by a company with the relevant certification (European Waste Catalogue 160504).

Only for United Kingdom

According to Waste Electrical and Electronic Equipment Regulations 2013 (SI 2013/3113) (as amended) devices that are no longer usable must be collected separately and disposed of in an environmentally friendly manner.

ORIGINAL EU Declaration of Conformity for a machine in accordance with 2006/42/EC, Annex II, Part 1, Section A	
1.	Machine: Dehumidifier DH
2.	Manufacturer: Trotec GmbH Grebbener Str. 7 52525 Heinsberg Germany online@trotec.com www.trotec.com
3.	./.
4.	This declaration of conformity is issued under the sole responsibility of the manufacturer.
5.	Object of the declaration: DH 20 Year of manufacture as of: 2024
6.	The object of the declaration described in point 5 is in conformity with the following Union harmonisation legislation: <ul style="list-style-type: none"> • 2006/42/EC • 2011/65/EU • 2014/30/EU
7.	Applied harmonised standards: <ul style="list-style-type: none"> • EN 60335-1:2012, EN 60335-1:2012/AC:2014, EN 60335-1:2012/A11:2014, EN 60335-1:2012/A13:2017, EN 60335-1:2012/A15:2021 (Official Journal 13/04/2022) • EN 60335-2-40:2003, EN 60335-2-40:2003/A11:2004, EN 60335-2-40:2003/A12:2005, EN 60335-2-40:2003/A1:2006, EN 60335-2-40:2003/A13:2012/AC:2013, EN 60335-2-40:2003/A13:2012, EN 60335-2-40:2003/A2:2009, EN 60335-2-40:2003/AC:2006, EN 60335-2-40:2003/AC:2010 (Official Journal 28/11/2013) • EN 61000-3-3:2013 (Official Journal 13/05/2016) <p>Common specifications applied: ./.</p> <p>Other applied standards and specifications: <ul style="list-style-type: none"> • CISPR 14-1:2020, CISPR 14-2:2020 • EN 61000-3-3:2013/A1:2019 • EN IEC 61000-3-2:2019, EN IEC 61000-3-2:2019/A1:2021 • EN IEC 55014-1:2021, EN IEC 55014-2:2021 • EN IEC 60335-2-40:2018 • IEC 61000-3-2:2018, IEC 61000-3-2:2018/AMD1:2020 • IEC 61000-3-3:2013, IEC 61000-3-3:2013/AMD:2017, IEC 61000-3-3:2013/AMD2:2021 </p>
8.	./.
9.	The machine is subject to the conformity assessment procedure on the basis of an internal production control.
10.	Other information: Authorised representative compiling the technical documentation: Trotec GmbH Grebbener Str. 7 52525 Heinsberg Germany

Heinsberg, 14 November 2024



Joachim Ludwig (Managing Director)

ORIGINAL EU Declaration of Conformity for a machine in accordance with 2006/42/EC, Annex II, Part 1, Section A	
1.	Machine: Dehumidifier DH
2.	Manufacturer: Trotec GmbH Grebbener Str. 7 52525 Heinsberg Germany online@trotec.com www.trotec.com
3.	./.
4.	This declaration of conformity is issued under the sole responsibility of the manufacturer.
5.	Object of the declaration: DH 35 / DH 35 H Year of manufacture as of: 2024
6.	The object of the declaration described in point 5 is in conformity with the following Union harmonisation legislation: <ul style="list-style-type: none"> • 2006/42/EC • 2011/65/EU • 2014/30/EU
7.	Applied harmonised standards: <ul style="list-style-type: none"> • EN 60335-1:2012, EN 60335-1:2012/AC:2014, EN 60335-1:2012/A11:2014, EN 60335-1:2012/A13:2017, EN 60335-1:2012/A15:2021 (Official Journal 13/04/2022) • EN 60335-2-40:2003, EN 60335-2-40:2003/A11:2004, EN 60335-2-40:2003/A12:2005, EN 60335-2-40:2003/A1:2006, EN 60335-2-40:2003/A13:2012/AC:2013, EN 60335-2-40:2003/A13:2012, EN 60335-2-40:2003/A2:2009, EN 60335-2-40:2003/AC:2006, EN 60335-2-40:2003/AC:2010 (Official Journal 28/11/2013) • EN 61000-3-3:2013 (Official Journal 13/05/2016)
	Common specifications applied: ./.
	Other applied standards and specifications: <ul style="list-style-type: none"> • CISPR 14-1:2020, CISPR 14-2:2020 • EN 61000-3-3:2013/A1:2019 • EN IEC 55014-1:2021, EN IEC 55014-2:2021 • EN IEC 60335-2-40:2018 • EN IEC 61000-3-2:2019, EN IEC 61000-3-2:2019/A1:2021 • IEC 60335-1:2020 • IEC 60335-1:2020/AMD1:2013, IEC 60335-1:2020/AMD2:2016 • IEC 61000-3-3:2013, IEC 61000-3-3:2013/AMD:2017, IEC 61000-3-3:2013/AMD2:2021 • IEC 61000-3-2:2018, IEC 61000-3-2:2018/AMD1:2020
8.	./.
9.	The machine is subject to the conformity assessment procedure on the basis of an internal production control.
10.	Other information: Authorised representative compiling the technical documentation: Trotec GmbH Grebbener Str. 7 52525 Heinsberg Germany

Heinsberg, 14 November 2024



Joachim Ludwig (Managing Director)

ORIGINAL EU Declaration of Conformity for a machine in accordance with 2006/42/EC, Annex II, Part 1, Section A		
1.	Machine:	Dehumidifier DH
2.	Manufacturer:	Trotec GmbH Grebbener Str. 7 52525 Heinsberg Germany online@trotec.com www.trotec.com
3.	./.	
4.	This declaration of conformity is issued under the sole responsibility of the manufacturer.	
5.	Object of the declaration:	DH 65 / DH 65 H Year of manufacture as of: 2024
6.	The object of the declaration described in point 5 is in conformity with the following Union harmonisation legislation:	<ul style="list-style-type: none"> • 2006/42/EC • 2011/65/EU • 2014/30/EU
7.	Applied harmonised standards:	
	<ul style="list-style-type: none"> • EN 60335-1:2012, EN 60335-1:2012/AC:2014, EN 60335-1:2012/A11:2014, EN 60335-1:2012/A13:2017, EN 60335-1:2012/A15:2021 (Official Journal 13/04/2022) • EN 60335-2-40:2003, EN 60335-2-40:2003/A11:2004, EN 60335-2-40:2003/A12:2005, EN 60335-2-40:2003/A1:2006, EN 60335-2-40:2003/A13:2012/AC:2013, EN 60335-2-40:2003/A13:2012, EN 60335-2-40:2003/A2:2009, EN 60335-2-40:2003/AC:2006, EN 60335-2-40:2003/AC:2010 (Official Journal 28/11/2013) 	
	Common specifications applied: ./.	
7.	Other applied standards and specifications:	
	<ul style="list-style-type: none"> • CISPR 14-1:2020, CISPR 14-2:2020 • EN IEC 55014-1:2021, EN IEC 55014-2:2021 • EN IEC 61000-3-2:2018, EN IEC 61000-3-2:2018/AMD1:2020 • EN IEC 61000-3-2:2019, EN IEC 61000-3-2:2019/A1:2021 • EN IEC 61000-6-2:2019 • EN IEC 61000-6-3:2019 • EN IEC 60335-2-40:2018 • IEC 60335-1:2010 • IEC 60335-1:2010/AMD1:2013, IEC 60335-1:2010/AMD2:2016 • IEC 61000-3-2:2018, IEC 61000-3-2:2018/AMD1:2020 • IEC 61000-3-3:2013, IEC 61000-3-3:2013/AMD:2017, IEC 61000-3-3:2013/AMD2:2021 	
	./.	
8.	./.	
9.	The machine is subject to the conformity assessment procedure on the basis of an internal production control.	
10.	Other information:	Authorised representative compiling the technical documentation: Trotec GmbH Grebbener Str. 7 52525 Heinsberg Germany

Heinsberg, 14 November 2024



Joachim Ludwig (Managing Director)

Dantherm Group

Grebener Straße 7
52525 Heinsberg
Germany
☎ +49 2452 962-0
online@trotec.com
www.trotec.com

Dantherm can accept no responsibility for possible errors and changes (en)
Der tages forbehold for trykfejl og ændringer (da)
Irrtümer und Änderungen vorbehalten (de)
Dantherm n'assume aucune responsabilité pour erreurs et modifications éventuelles (fr)

